

Processing Unit

HIP - 1200

(Subject : Ver.1.21 ~)

User's Manual

- 5.1th edition -

Suruga Seiki Co., Ltd.

Thank you for choosing Suruga Seiki's product. This manual has been written for the operation of Processing Unit PRO HIP-1200. For proper use, please read this user's manual thoroughly prior to using this product and keep it for future reference.

●Cautions for Your Safety

For proper and effective use, please read this manual thoroughly prior to using this product.

Failure to use the product properly as explained in the manual may cause damage or injury. The sign  indicates prohibited actions.

 **Cautions**

• Safety & Proper Operation

- This product is connected to Laser Auto Collimator. Therefore, an operator of this product should have knowledge of handling laser equipment safety.

• Wiring

- When connecting or disconnecting a cable, turn off the power of this product and any instrument connected to the product. Otherwise, it may cause damage to the product.
- Make sure to arrange wiring of I/O connector correctly. Otherwise, it may cause damage to the product.
- Make sure to insulate this product to prevent electric shock.

• Operating Environment

Do not use the product in the following environments:

- Directly under sunlight
- Areas that have much dust or metallic particles
- Near fire
- Much noise, much vibration
- Areas that may have water or oil spill
- Not flat surface
- Corrosive gas and/or flammable gas environment

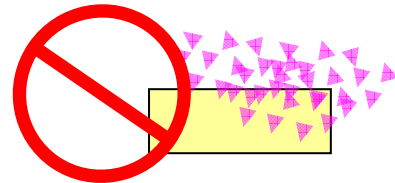

• Disassembling/Alteration

DO NOT disassemble, alter, or perform any improper repair of this product. It may cause electric shock. If you have any question trouble, please contact us.



• Repair Request

In case of the following conditions, please unplug a power cable immediately and contact us for repair request. If the product is continuously used, it may cause fire, electric shock or injury.

- Strange sound or smell or smoke coming out of the product
- Power cable is damaged
- Water is spilled over or foreign particle got inside the product
- Product was dropped or cabinet was damaged

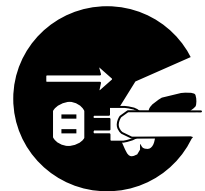

I N D E X

1. INTRODUCTION	4
1.1 PROCESSING FUNCTION	4
1.2 PRINCIPLE OF MEASUREMENT USING A LASER AUTO COLLIMATOR	7
2. PREPARATION	12
2.1. ASSEMBLING.....	12
2.2. CONNECTIONS.....	15
2.3. POWER ON.....	17
2.4. MAIN SCREEN.....	18
3. SYSTEM SETTING.....	19
3.1. NEW SETTING (SYSTEM SETTING).....	19
3.2. SETTING SCREEN & CONTENTS.....	21
3.3. BINARY.....	22
3.4. CALIBRATE.....	23
3.5. ROTATION.....	23
3.6. MIRRORING.....	24
3.7. DISPLAY.....	25
3.8. UNIT.....	25
3.9. COM.....	25
3.10. DATA OUT.....	26
3.11. KEY LOCK.....	26
3.12. REMOTE.....	27
3.13. SAVE.....	27
4. ANGLE MEASUREMENT.....	28
4.1. SINGLE MEASUREMENT BASIC FUNCTIONS.....	28
4.2. MULTI (RELATIVE) MEASUREMENT BASIC FUNCTIONS [MULTI R.].....	30
4.3. MULTI (ABSOLUTE) MEASUREMENT BASIC FUNCTIONS [MULTI A.].....	31
4.4. OFFSET TILT MEASUREMENT BASIC FUNCTIONS.....	32
5. ANGLE MEASUREMENT SETTING.....	33
5.1. ANGLE MEASUREMENT USAGE.....	33
5.2. SETTING SCREEN & CONTENTS.....	35
5.3. ZERO SET.....	36
5.4. ZERO RESET.....	37
5.5. MODE.....	37
5.6. LABEL SEL.....	43
5.7. NUMBERING.....	47
5.8. TOLERANCE.....	47
5.9. AVERAGE.....	50
5.10. ZOOM.....	51
5.11. LOAD.....	53
5.12. SAVE.....	53

6. RUNOUT MEASUREMENT	54
6.1. RUNOUT MEASUREMENT BASIC FUNCTIONS.....	54
7. RUNOUT MEASUREMENT SETTING	55
7.1. RUNOUT MEASUREMENT USAGE.....	55
7.2. SETTING SCREEN & CONTENTS.....	57
7.3. ZERO SET	58
7.4. ZERO RESET.....	59
7.5. SAMPLE	59
7.6. BINARY.....	60
7.7. CALC MODE.....	61
7.8. TOLERANCE.....	61
7.9. WIDTH.....	63
7.10. LOAD.....	64
7.11. SAVE.....	64
8. 3 BEAM MEASUREMENT	65
8.1. SUB-BEAM TILT ANGLE MEASUREMENT BASIC FUNCTIONS.....	65
8.2. MAIN BEAM MEASUREMENT BASIC FUNCTIONS	66
9. 3BEAM MEASUREMENT SETTING.....	67
9.1. 3BEAM MEASUREMENT USAGE.....	67
9.2. SETTING SCREEN & CONTENTS	69
9.3. ZERO SET	70
9.4. ZERO RESET.....	71
9.5. THRESHOLD	71
9.6. NOIZE CHK.....	72
9.7. TOLERANCE.....	73
9.8. θ ANGLE	74
9.9. LOAD.....	75
9.10. SAVE.....	75
10. ANGLE CALIBRATION.....	76
10.1. ABOUT ANGLE CALIBRATION	76
10.2. FLOW OF ANGLE CALIBRATION	77
10.3. CALIBRATION MENU (SYSTEM-CALIBRATE).....	78
11. ERROR MESSAGE.....	82
12. EXTERNAL CONTROL	83
12.1. SERIAL INTERFACE.....	83
12.2. COMMUNICATION COMMANDS.....	85
12.3 COMMUNICATION FORMAT	86
12.4. DATA COLLECTION SOFTWARE.....	103
12.5. I/O.....	104
13. TROUBLESHOOTING	106

1. INTRODUCTION

1.1 Processing Function

The HIP-1200 Processing Unit receives and digitally processes the signals from Suruga Seiki's Auto Collimator, and displays the detected angles and the result of acceptance range on an external monitor screen.

The unit has "angle measurement," "runout measurement" and "3 BEAM measurement" functions. The results of measurement can be transferred to a personal computer.

Connected Image Chart

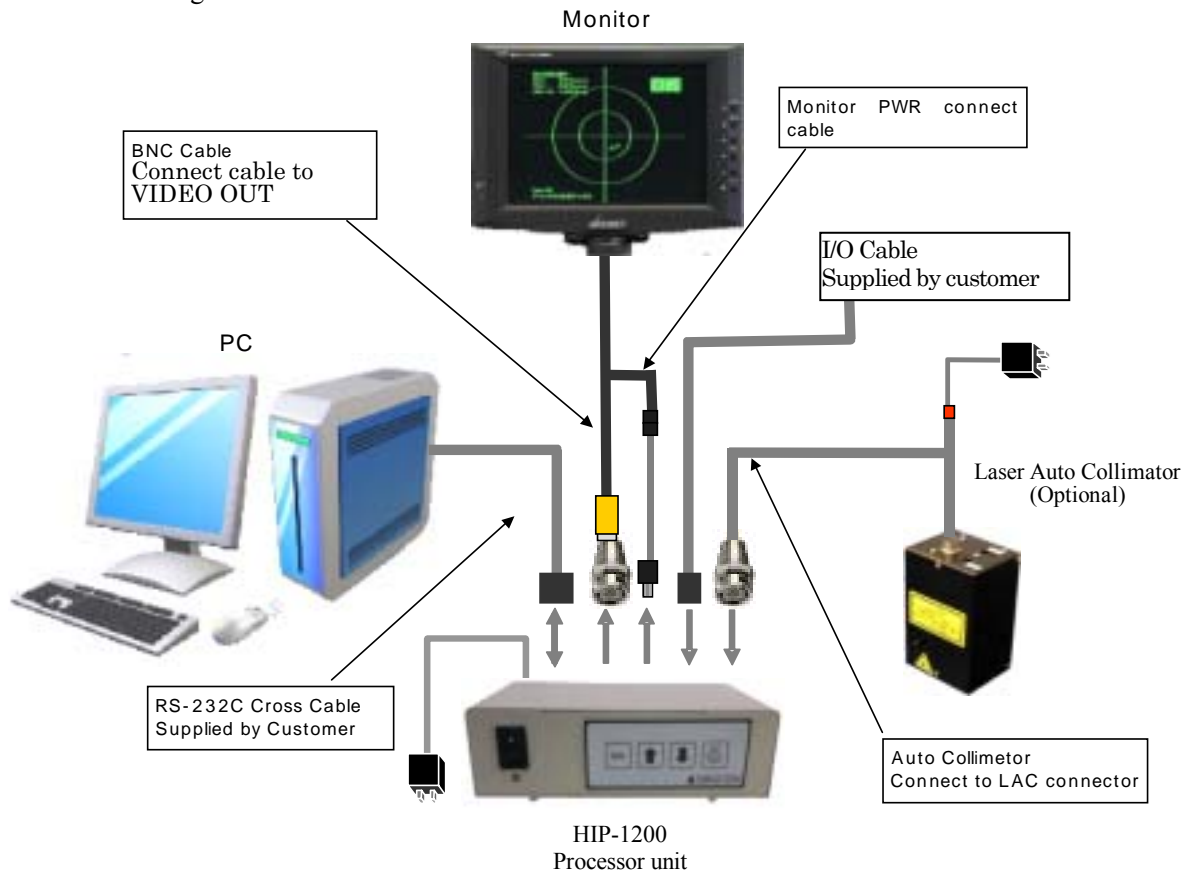

• Feature

There are 3 kinds of centroid analysis at when measure the angle. (Center of area, Luminance Centroid, Luminance Peak)



Improved MultiPoint measurement function.

Rotation (Switch X Y coordinates) Mirroring / Offset judgment

(Setting can be changed for subtle difference of setting and operation direction)

Include Command control by serial communication as standard equipment.

~ Good for process that need MultiSpot measurement ~

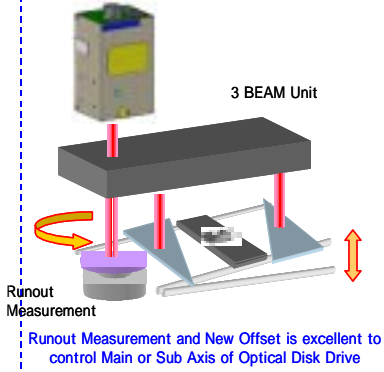
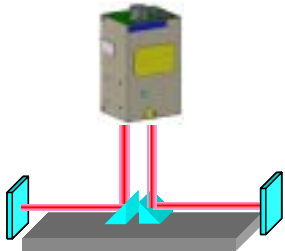
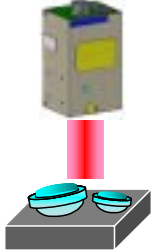
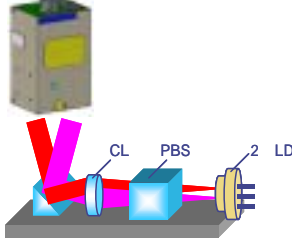
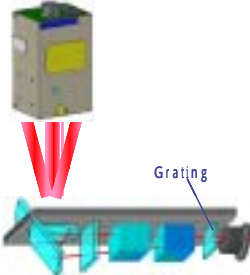
➤Digital Camera / Cell Phone Camera Module / Vehicle video system			➤Optical Disk Drive
			
<p>New MultiSpot is excellent for Parallel Control between two Optical Elements</p>	<p>New MultiSpot is excellent for The Measurement Tilt of Image Sensor</p>	<p>New MultiSpot is excellent for Parallel Control between Image Sensor and Optical Elements</p>	<p>Runout Measurement and New Offset is excellent to control Main or Sub Axis of Optical Disk Drive</p>
➤Optical Pickup			
			
<p>Blu-ray and CD/DVD New MultiSpot is excellent for 2 Beam Mirror Control</p>	<p>Blu-ray and CD/DVD New MultiSpot and Offset function are excellent for 2 Pickup Lens adjustment</p>	<p>2 LD New Offset function is excellent to control Optical Axis and Rotation</p>	<p>Grating Grating Rotation Control New Feature 3 BEAM is excellent for Measurement</p>

• Specification

Item	Specification
Image output signal	NTSC color image signal (BNC)
Operation environment	0 ~ 40°C, 20 ~ 80%RH (no condensation)
Power consumption	DC12V 1 A
Parallel I/O	Insulated type I/O, in:3port, out:1port
Communication port	RS-232C (D-SUB 9-pin)
Size	W160 × H50 × D105mm (including the rubber legs of 9mm)
Weight	600g

*Appearance and specifications of this product are subject to change for upgrade without advance notice.

• Function list

	Function	Old Version	The Product
Angle Measurement (Standard Measurement Function)	Single Spot	○	○
	Multi Spot (Level ordering)	○ (Detection Ordering)	○ (Size Number / Angle Ordering)
Angle Measurement (Application Function)	Runout Measurement (Precision Motor Deflection Measurement)	○	○
	DCTilt Measurement (Actuator Tilt)	×	○
	3 BEAM Measurement (Gearing Rotation Control)	×	○
Angle Analysis	Center of area	○	○
	Luminance centroid	○	○
	Luminance peak	×	○
User-Friendly Function	Display the luminance value	×	○
	Zoom function	×	○
	(Switch XY axis)	×	○
	Inverting image	×	○
Judgment of Acceptance	Circle	○	○
Range of Acceptance	Square (Rad/Tan)	○	○
Judgment of Acceptance	Offset Judgment	×	○
Judgment Condition	MultiSpot Selected points	×	○
	MultiSpot All points	×	○
Parallel I/O	I / O Points	8 / 8	3 / 1
	Input Function1 Zero Set	○	○
	Input Function 2 Data Output	○	○
	Input Function 3	○ (Due to each function)	○ (Due to each function)
	Output Function	Judgment of Acceptance	Judgment of Acceptance
Serial Communication	Interface	RS-232C	RS-232C
	Command Control	○	○
	Data Output	CSV Style	CSV Style

1.2 Principle of Measurement Using a Laser Auto Collimator

Light emitted from the semiconductor laser is transformed into parallel laser light by the collimating lens. The laser light that is reflected by the half-mirror back to reflect to object, then collected by collective lens, and focused onto CCD that set on focal length.

Can be measuring object tilt according to get the length of focus point on the CCD.

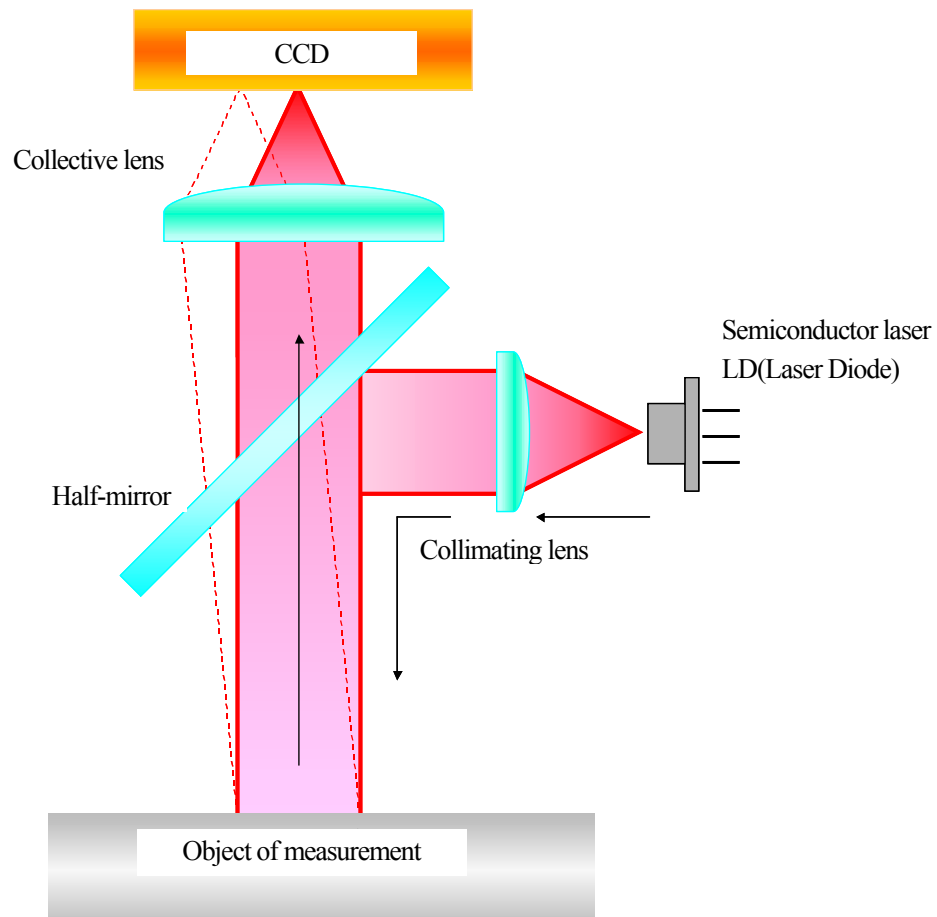

1.2.1. Principles of Reflection and External Incidence Measurements

In reflection measurement using a common internal laser light source, the optical axis of the reflected light is entered into an autocollimator in double tilt of $\alpha/2$

In an autocollimator, α that adjusts tilt of the laser of this $2X \alpha$ a half is displayed as a tilt angle of the measurement object. When measuring the tilt of external laser light source, should be display the angle of incidence of the laser (β) as a measurement angle. Therefore it must be setup reflection measurement or external incident measurement. (see “1.2.2 Switching to External Incidence Measurement” below).

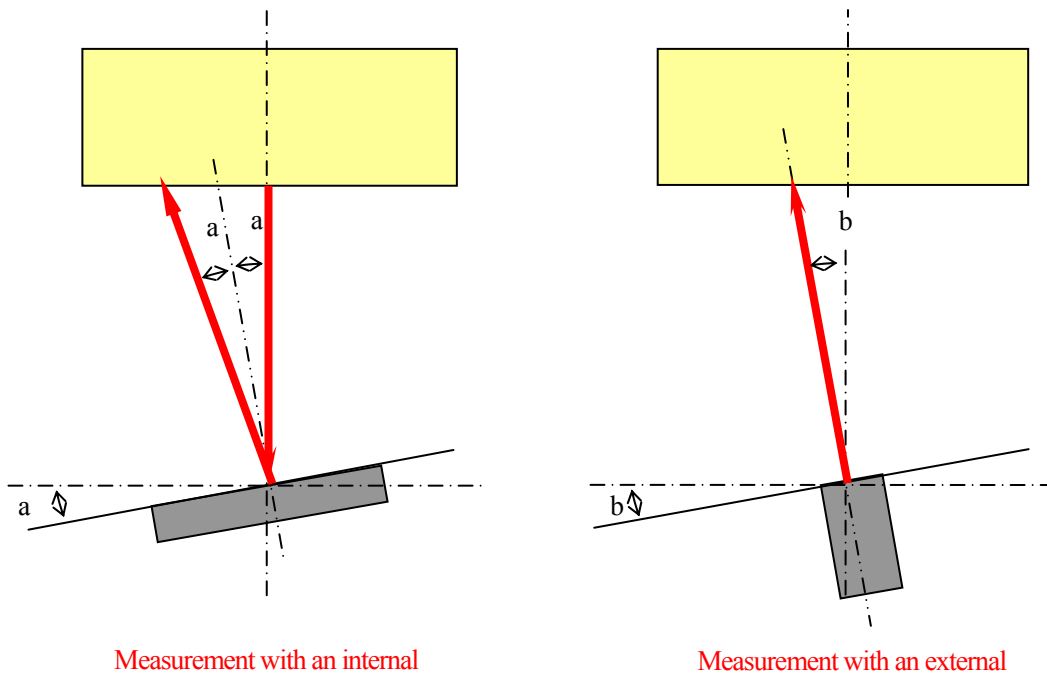

1.2.2. Switching to External Incidence Measurement

Turn power off. Locate the DIP switch in back of the unit and set No.3 pin to ON and all other pins to OFF. The unit will start in external incidence measurement mode when it is turned on.

1) DIP switch

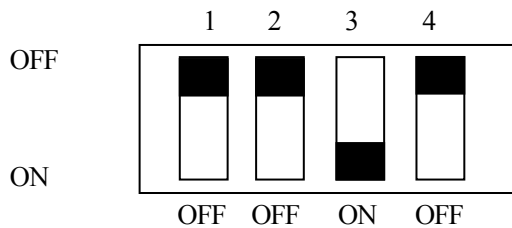

(Note)

- No.3 pin sets OFF for shipment.
- When the calibration is performed, return the DIP switch and checked with internal light source.
See “10. Angle Calibration” for detailed information.

1.2.3. Screens in External Incidence Measurement Mode

- Measurement screen

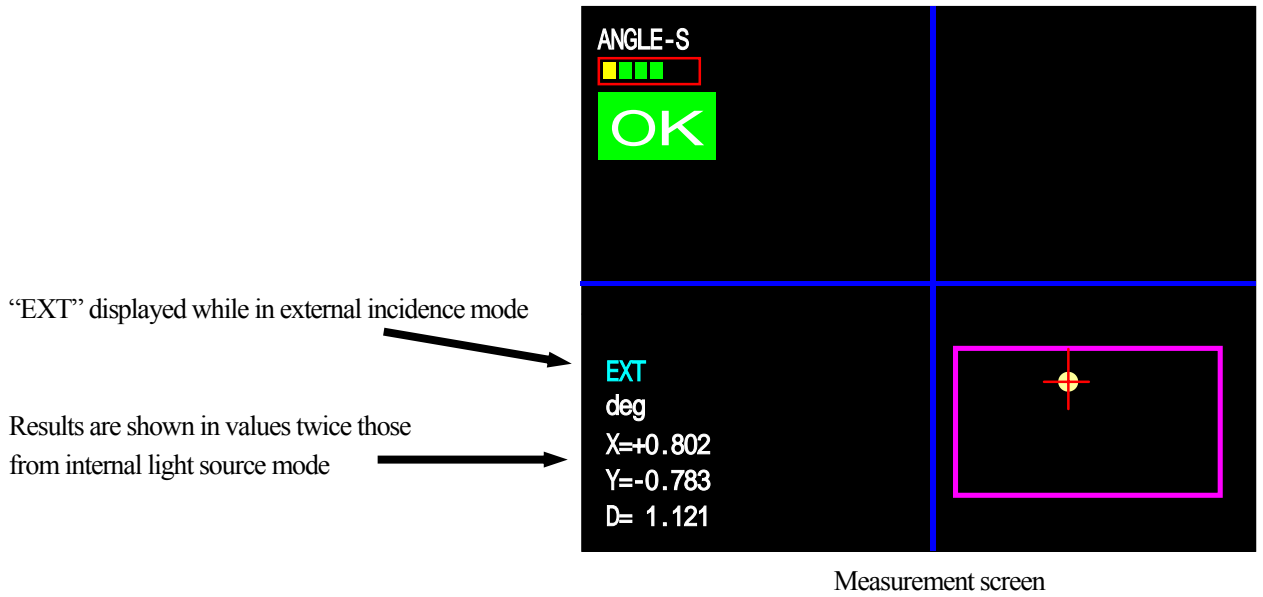

(Note)

- Serial input data format is no different between internal and external light source

• Accessories & Options

This Product comes with the following accessories. Please check if everything is included.

- AC adapter 1
- Laser Auto Collimator - HIP-1200 Video Cable 1
(model : HIP-1200C)
- User's Manual 1

Accessory detailed

1)AC adapter

Size :
 Weight : 120g
 Rating : AC100 ~ 240V
 DC12V 1A or more



2)Laser Auto Collimator - HIP-1200 Video Cable(model : HIP-1200C)

Size : 1.5m
 Weight : 80g



3)User's Manual

Size : A4
 Weight : 240g

The following option items are available to meet your needs. Please contact us for purchasing option items.

Product		Model	Note
Laser Auto Collimator	Small type with red LD	H350R-C□□□	Measuring Range $\pm 0.5^\circ \sim \pm 1.0^\circ$
	Small type with blue LD	H350B-C□□□	Measuring Range $\pm 0.5^\circ \sim \pm 1.0^\circ$
	With red LD	H400-C□□□	Measuring Range $\pm 0.5^\circ \sim \pm 2.0^\circ$
	With red LD and screen	H400-C□□□S	Measuring Range $\pm 0.16^\circ \sim \pm 0.35^\circ$
	V-type LAC with red LD	H450R-C□□□	Measuring Range $\pm 0.5^\circ \sim \pm 1.5^\circ$
	V-type LAC with blue LD	H450B-C□□□	Measuring Range $\pm 0.5^\circ \sim \pm 1.5^\circ$
	For 2 wavelength (with screen)	H600-C□□□S	Measuring Range $\pm 0.2^\circ, \pm 0.3^\circ$
	For 2 wavelength with red and blue LDs	H600B-C□□□S	Measuring Range $\pm 0.2^\circ, \pm 0.3^\circ$
2-axes Tilt Stage		HB10	For H400-C, H350
		HB11	For H400-CS, H450, H600-CS
Mount		HA10	
		HA11N	High Stiffness Type
Parallel Mirror		HS-0	$\phi 30, t=10$, One side AL coating Parallelism less than 5arcsec.
Wedged Substrate	1° (60 arcmin)	HS-100	$\phi 40, t=10$ Angle accuracy less than ± 10 arcsec.
	0.5° (30 arcmin)	HS-050	
	0.25°(15 arcmin)	HS-025	
	0.2° (12 arcmin)	HS-020	
	0.1° (6 arcmin)	HS-010	
Wedged Mirror	1° (60 arcmin)	HS-100AL	$\phi 40, t=10$ Angle accuracy less than ± 10 arcsec. AL+MgF ₂
	0.5° (30 arcmin)	HS-050AL	
	0.25°(15 arcmin)	HS-025AL	
	0.2° (12 arcmin)	HS-020AL	
	0.1° (6arcmin)	HS-010AL	
Monitor		VCM-562W	

2. PREPARATION

This manual assumes the use of Suruga Seiki's Laser Autocollimator (H400 series), 2-axes tilt stage (HB10) and parallel mirror (HS-0). Set those or other units as instructed below.

2.1. Assembling

Attach the Laser Auto Collimator to the 2-axes tilt stage (HB10) and mount the parallel mirror (HS-0). Keep the distance between the laser output of the Laser Auto Collimator and the parallel mirror (HS-0) to the work distance of the Laser Auto Collimator heads (as shown below).

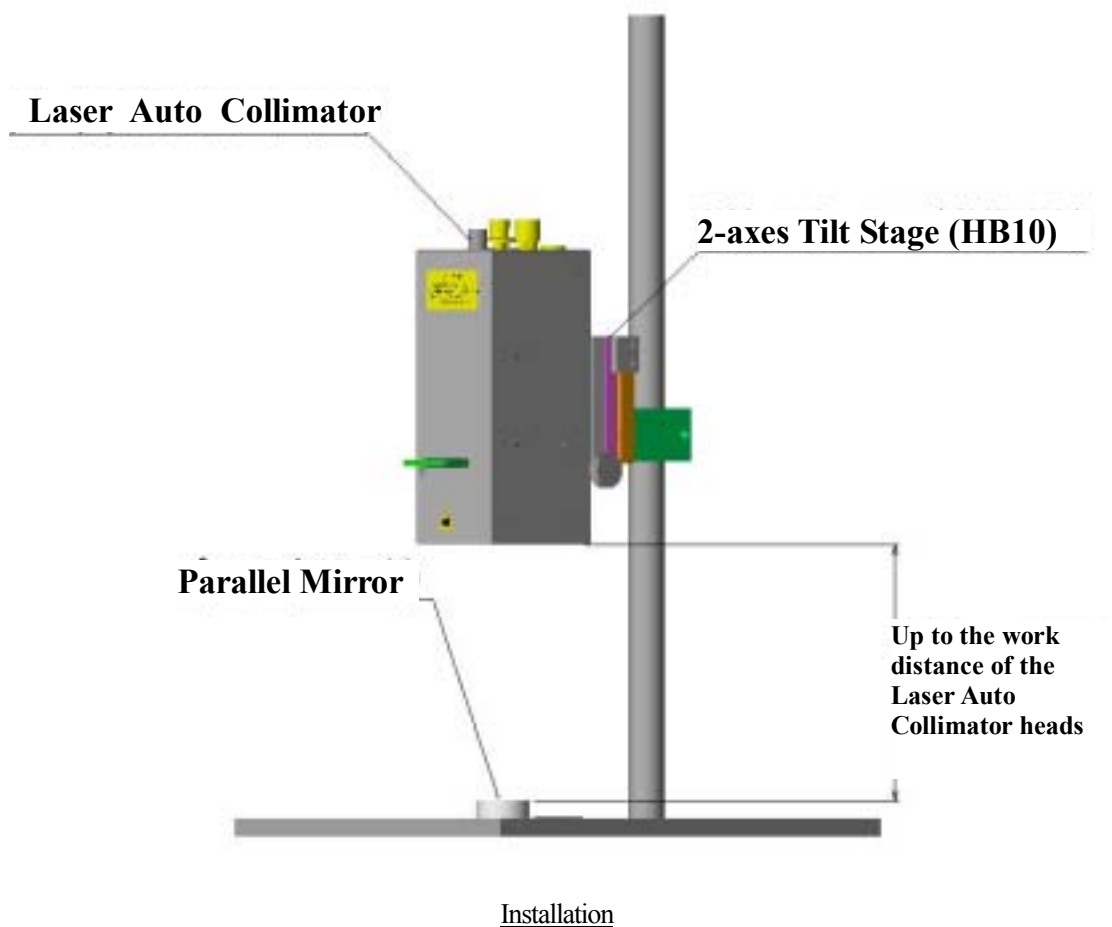

Refer to the following pages about the detailed method of assembling the stand and the tilt stage (if applicable).

• 2.1.1 Assembling method

Screw on the tilt stage to stand.

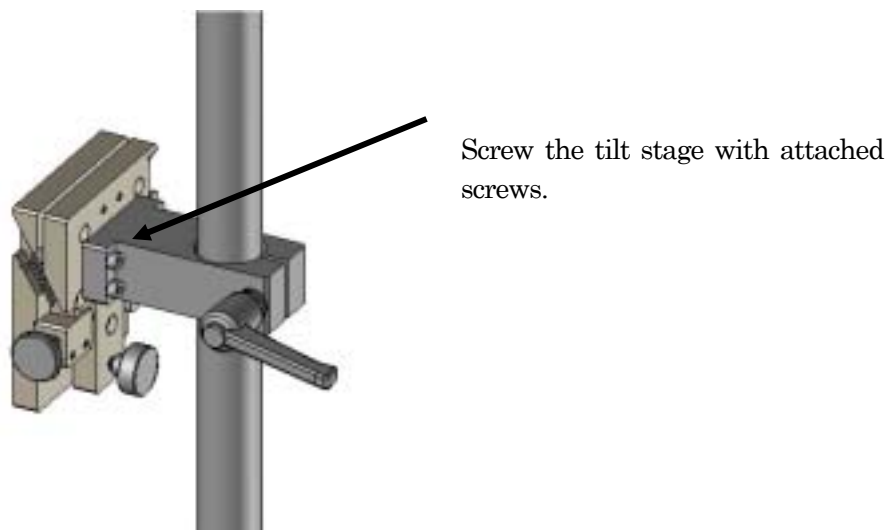

The tilt stage may be installed horizontally. In that case, place it in such a way the flat surface of the opposing knob seats is below the tapered surface as shown (along the direction of spring tension).

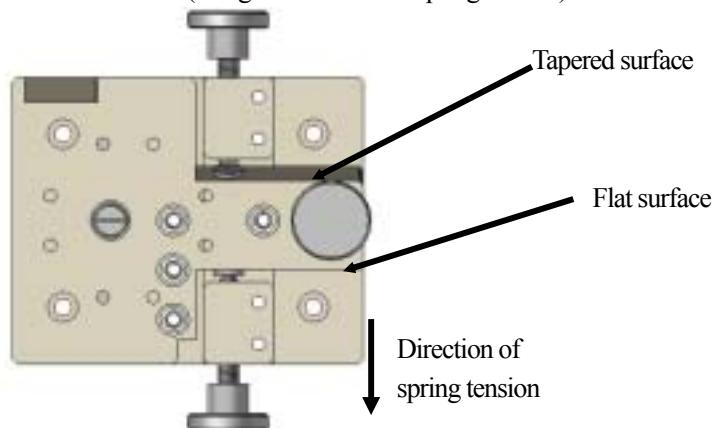

Screw the autocollimator with attached screws.

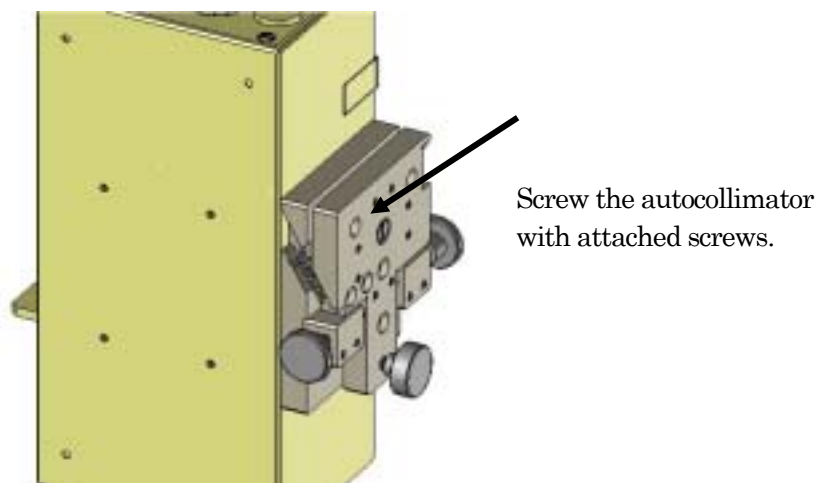

Can be controlled X, Y and Z with tilt stage. Also control X, Y with right and left knob, center nob can be controlled Z. Clamp the tilt stage with squeezing the front knob in tapered side.(see next page)

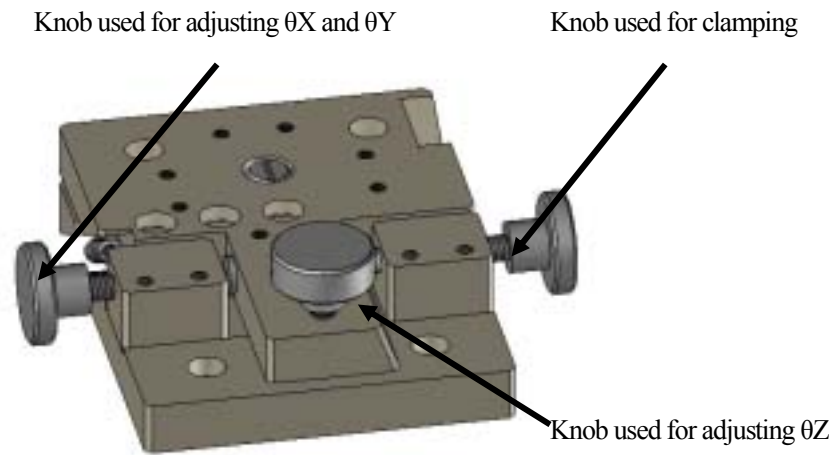

2.1.2 Adjusting method

- 1) Adjust the detected light to the desired position by rotating the right and left knobs (θX , θY) and the middle knob (θZ).
- 2) Retighten the right and left knobs as needed for clamping.
- 3) Finally, retighten the middle knob (θZ) as needed for pressurizing.

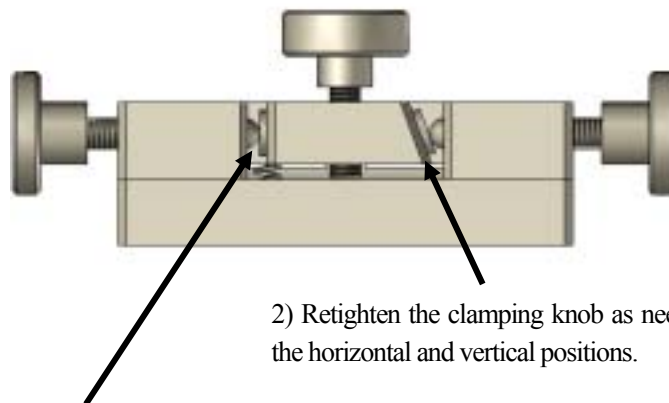

- 3) After clamping, retighten the middle knob (θZ) as needed for pressurizing.

2.2. Connections

2.2.1. Names of Components & Functions

Front Panel

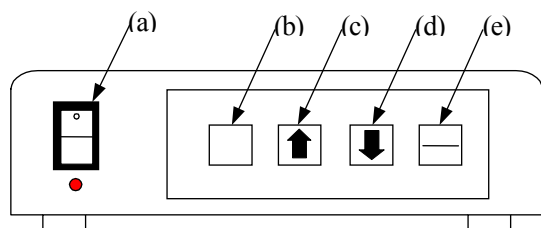

Back Panel

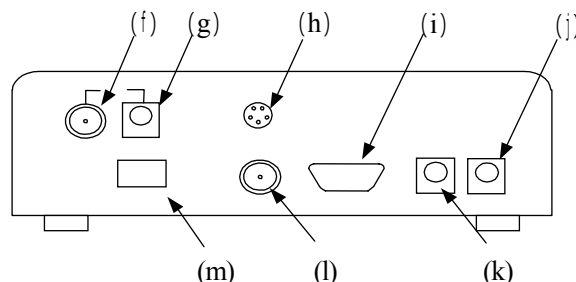

No.	Name	Function
(a)	Power Switch	Switch to turn on or off the power
(b)	[MENU] Key	Switch the setting screens (or cancel settings)
(c)	[↑] Key	At Setting screen, press this to select items. Remote Mode should be cancelled when hold down a key for over 3 seconds.
(d)	[↓] Key	At Setting screen, press this to select items. Key Lock should be cancelled when hold down a key for over 3 seconds.
(e)	[ENT/ZERO] Key	At Setting Screen press this to fix the setting contents. ZERO SET should be operated when hold down a key for over 3 seconds at the Angle Measurement Screen.
(f)	LAC Connector (LAC)	Connecting Laser Autocollimator's cable connector (BNC)
(g)	Power supply for LAC (DC-OUT)	Service Power supply for Autocollimator (DC12V/0.5A)
(h)	I/O Connector (I/O)	For wiring input-output signals with external instruments
(i)	Communication Connector (D-sub 9-pin, male)	Cross cable for connecting to the RS232 port of the PC
(j)	DC Jack (DC12V-IN)	Connect the dedicated AC Adapter (AC100V ~ 240V required
(k)	Power Source for LCD Monitor (DC-OUT)	Power source for LCD monitor (12VDC/0.5A)*1
(l)	Monitor Output Connector (V-OUT)	For connecting monitor with BNC cable.
(m)	DIP switch	Optional setting (See 1.2.2. Connecting with External Instruments")

1 When connect VCM-562W to the power supply for LCD monitor (k), do not use adaptor provided in LCD monitor.

System Configuration

H350 Series

(HIP Set 1200 / Monitor&HIP Set 1200 / Full Set 1200)

AC100~240V

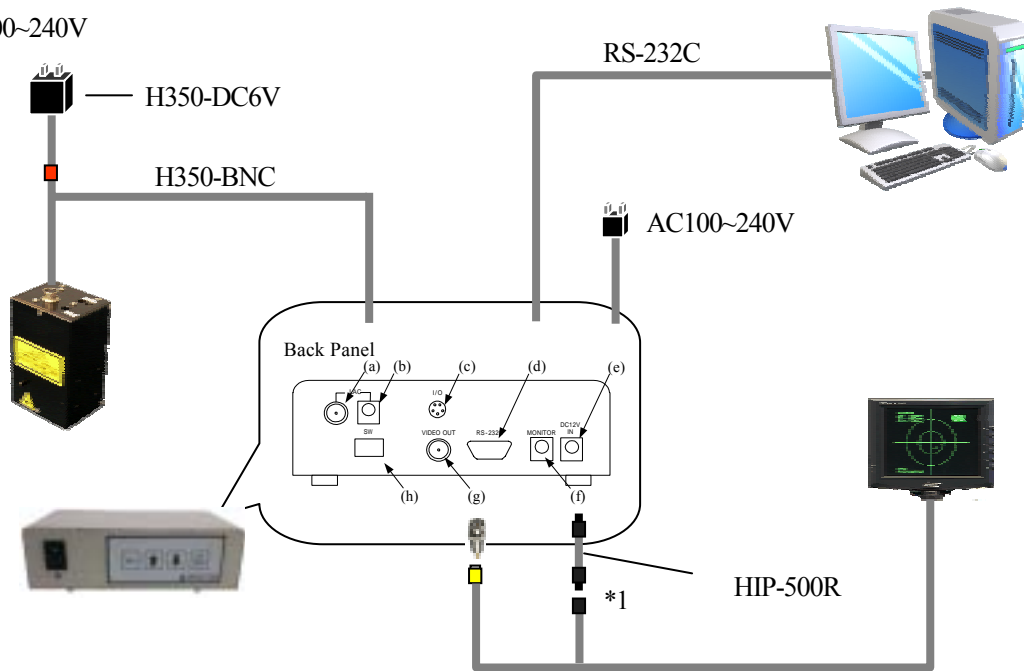

H400 / H450 / H600 Series

(HIP Set 1200 / Monitor&HIP Set 1200 / Full Set 1200 / High rigidity Set 1200)

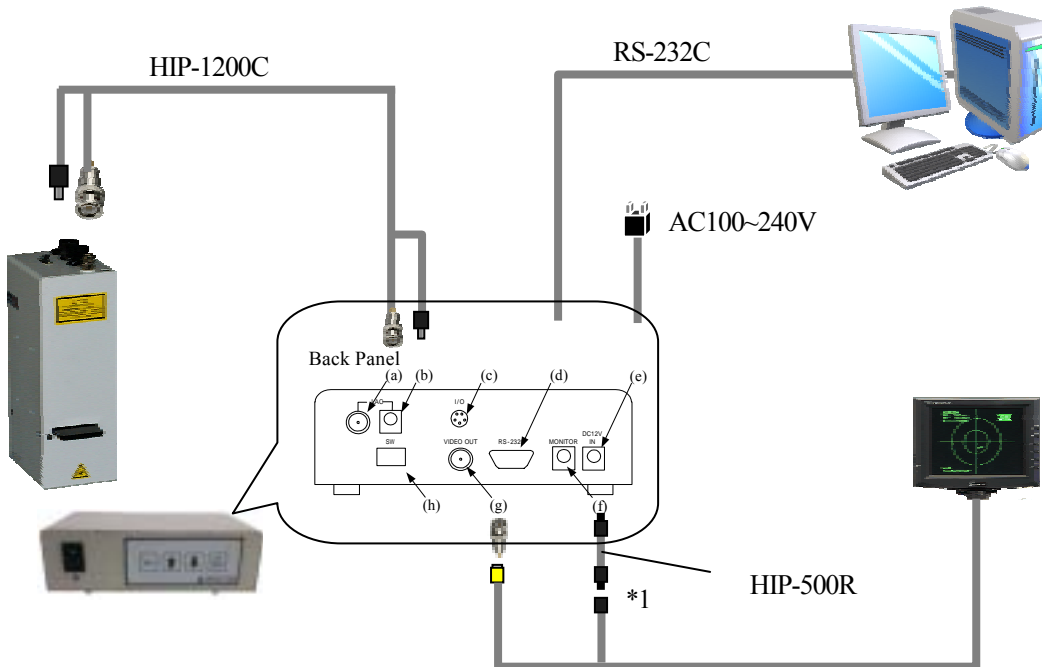

*1: The power cable for connecting HIP-1200 to the LCD monitor (VCM-562W) power source is provided with the LCD monitor. The AC adaptor attached to the LCD monitor is left unused.

2.3. POWER ON

Switch on the monitor, HIP-1200, and the Laser Auto Collimator in this order.

The soft version number is displayed at the end of right side on main screen

(No image each measurement screen and setting screen)

CAUTION: May be loose any data that one has not saved when power off.

2.4. Main Screen

The processing unit operations are set after assembling and connections are completed.

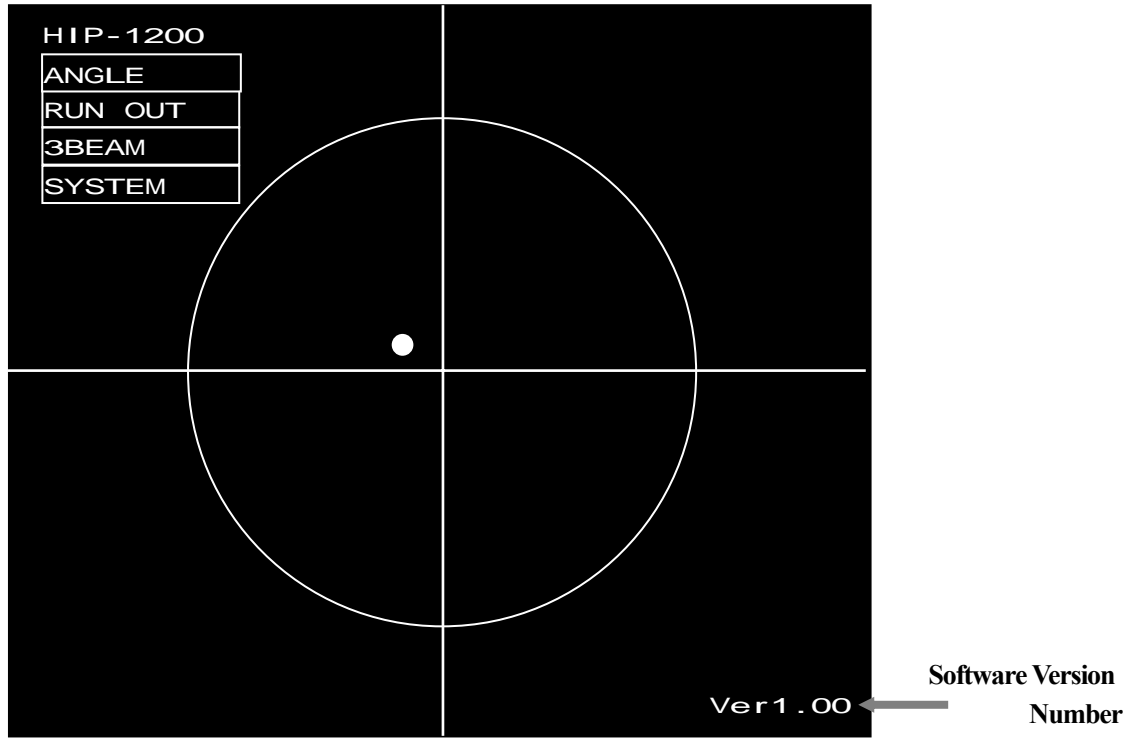

Main Screen

Setting Items

Name	Content Description	Page
ANGLE	Perform angle measurement. Adjust tilt angle of incident collimated light. Label and measure up to 3 collimating points. Calculate tilt angle of specified light spot and make OK/NG decision. (Setting items: decision basis, centroid calculation method, measurement type, order of labels, tolerance range, averaging, zoom)	4
RUN OUT	Perform runout measurement. Measure surface runout. Calculate centroid of surface runout. Calculate tilt angle of centroid and make OK/NG decision. (Setting items: Decision basis, frequency of sampling, binarization threshold, width calculation method, tolerance range of slant, tolerance range of run-out width)	6
3BEAM	Perform 3 BEAM measurement. Adjust tilt angles of sub-beams for tracking. Measure θ rotation angles of sub-beams. Measure tilt angle of main beam and make OK/NG decision. (Setting items: Decision basis, noise level, tolerance range of tilt, θ reference angle, tolerance range of θ angle, bar display range, averaging)	8
SYSTEM	Common settings for all measurements. (Setting items: Image rotation, image mirroring, display of measured values, units of display, baud rate, data output method, binarization threshold for calibration, calibration, save)	3

3. System Setting

3.1. New Setting (System Setting)

System setting is required before using the processing unit for the first time or whenever resetting of measurement conditions is necessary.

Follow setting steps shown below and see the applicable sections (numbers written to the left) for details.

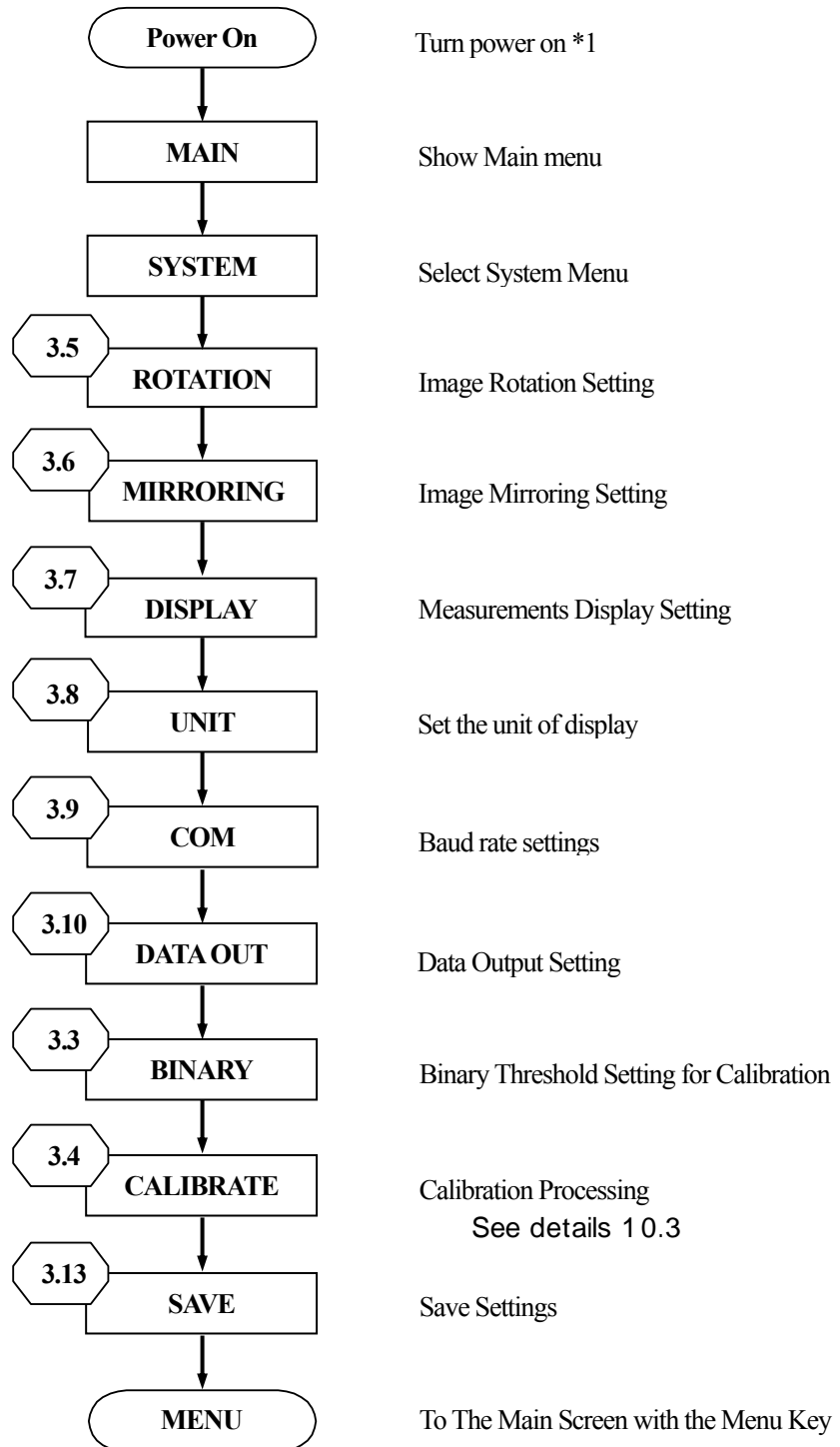

(Note)

- Default settings assuming the use of the Laser Auto Collimator are stored in FILE1 before shipment from the factory. Load FILE1 when you wish to return to default settings.
- Do not overwrite FILE1. Otherwise, all default settings will be lost.
- **At power on, the processing unit starts using the file number saved or loaded last and the mode of operation chosen last before power off.**
- Whenever settings are altered, save the new data for future use.

*1 **“Load ERROR!!” will appear when the saved data contain an error at power on.**

When this occurs, select OK in the memory initialization confirmation screen and start again. Angle calibration is required after memory initialization. See “10. ANGLE CALIBRATION” for details about angle calibration.

3.2. Setting Screen & Contents

SYSTEM	
BINARY	128
CALIBRATE	0.000481 deg / pixel
ROTATION	R90
MIRRORING	X-Y OFF
DISPLAY	ON
UNIT	min+sec
COM	19200
DATA OUT	I/O <input type="radio"/>
KEY LOCK	OFF
REMOTE	OFF
SAVE	

Setting Screen

Setting Items

Name	Content Description	Setting Value	Page
BINARY	Set the binary threshold at the calibration.	30~254	3.3
CALIBRATE	Set the calibration	-	3.4
ROTATION	Set the image rotation (Use at the X and Y axis switching.)	Left 90°Rotation Right 90°Rotation No Rotation	3.5
MIRRORING	Set the image mirroring .	Mirroring only Xdirection Mirroring only Ydirection Mirroring X,Ydirection No mirroring	3.6
DISPLAY	Set the display existence of measurements.	ON / OFF	3.7
UNIT	Set the unit.	min+sec / deg / mrad	3.8
COM	For selecting communication speed with PC.	9600 / 19200 38400 / 57600	3.9
DATA OUT	Set the measurement result output.	I/O / STREAM	3.10.
KEY LOCK	Set the key lock.	-	3.11
REMOTE	Set the remote control mode.	-	3.12
SAVE	Saving the setting data	1~5	3.13

3.3. BINARY

The binary threshold of the calibration is set.

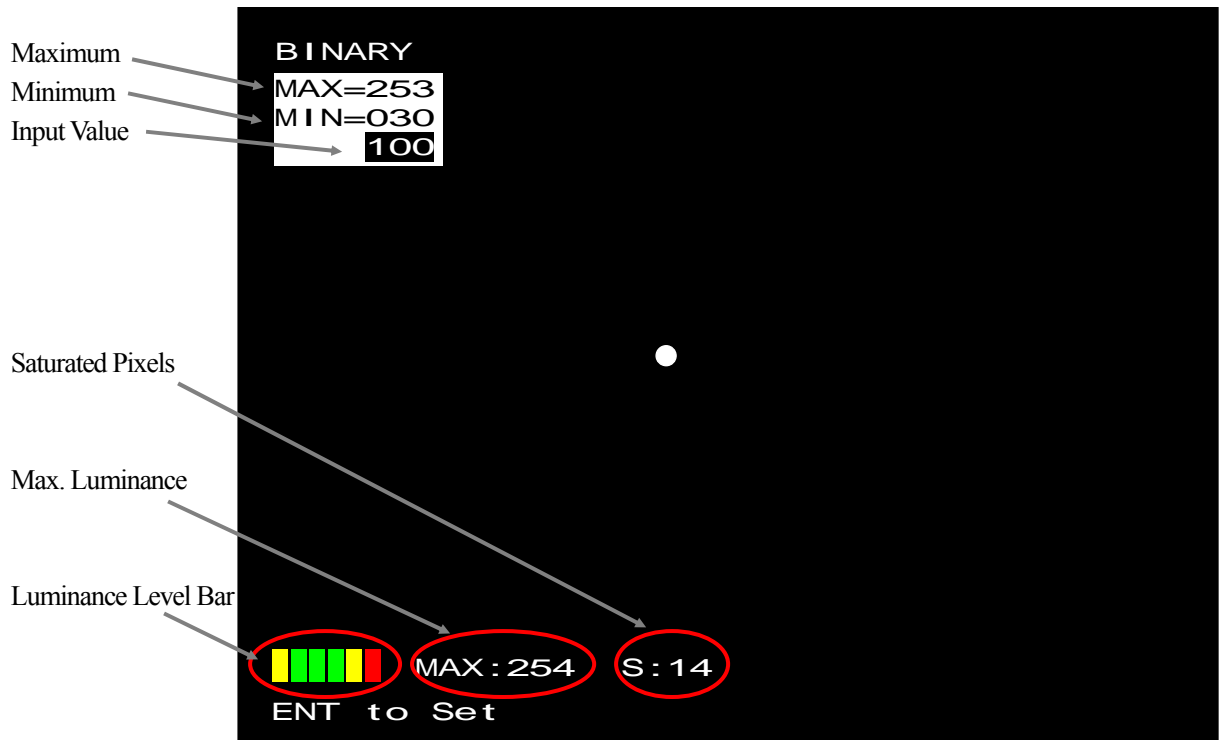

Setting Screen

- 1) Maximum : Input maximum value
- 2) Minimum : Input minimum value
- 3) Input Value :
 - ⬆ Key : Threshold increase
 - ⬇ Key : Threshold decrease
 - ENT Key : OK
 - MENU Key : Cancel
- 4) Saturated Pixels : Luminance is pixels of 254 or more
- 5) Max. Luminance : Video Max. luminance
- 6) Luminance Level Bar : See "4.1. Luminance Level Bar"

3.4. CALIBRATE

Calibration operation.

See Section 10 for details about calibration.

This setting can only be achieved while in reflection measurement mode (not in external incidence measurement mode).

3.5. ROTATION

Setting image rotation.

This function is used to match the jig direction and the \bar{Y} direction of spot movement in the monitor screen.

Only the image is rotated. The coordinate signs remain unchanged.



- 1) OFF : No image rotation
- 2) L90 : The image rotates 90 degrees to the left.
- 3) R90 : The image rotates 90 degrees to the right.

Example of processing:

Rotate the obtained image 90 degrees to the left or right.

1) No image rotation

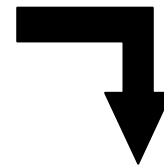
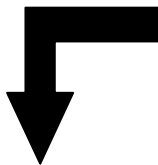
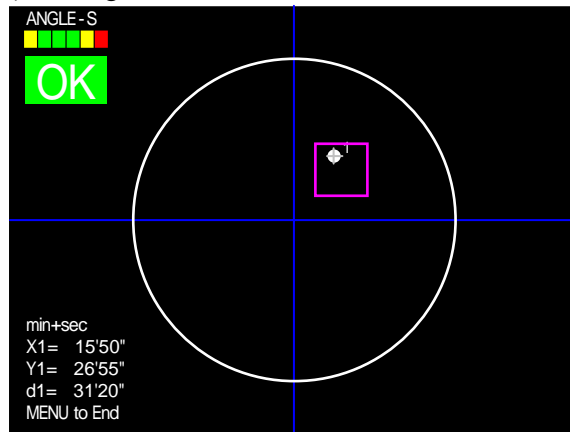

2) L90 (90-degree rotation to the left)

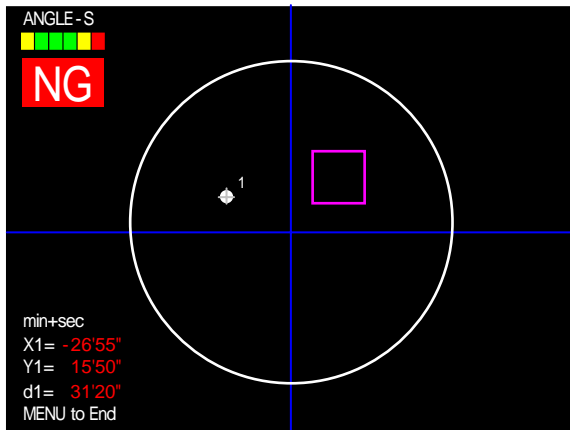

3) R90 (90-degree rotation to the right)

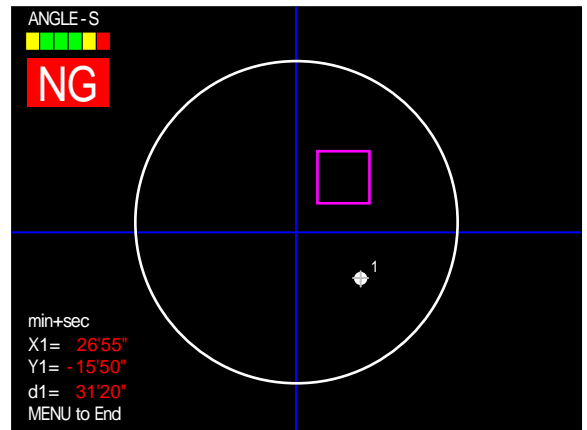

3.6. MIRRORING

Image mirroring setup of X and the direction of Y is performed.

While the system is in the image mirroring mode, the image is not displayed in the measurement screen. Instead, a reticle is displayed where the light spot is. When the object is moved and the spot moves in a wrong direction, the image is reverted to align the movement.

MIRRORING	X ON
	Y ON
	X-Y ON
	X-Y OFF

- 1) X ON : Image reverted in X direction
- 2) Y ON : Image reverted in Y direction
- 3) X-Y ON : Image reverted in X and Y directions
- 4) X-Y OFF : Image not reverted (intact)

Example of processing

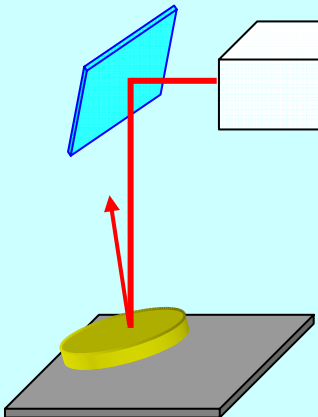

Mirror tilted to the left

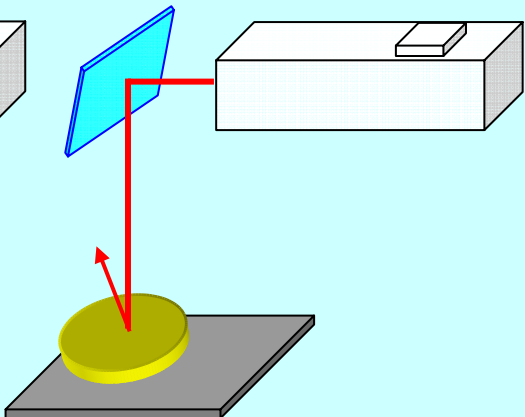

Mirror tilted to the foreground

(Monitor)

Direction of spot movement

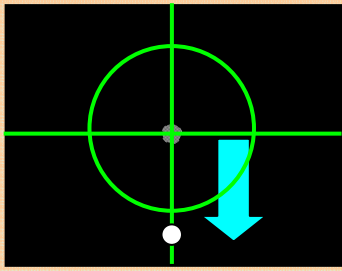

Normal setting

(Monitor)

Direction of spot movement

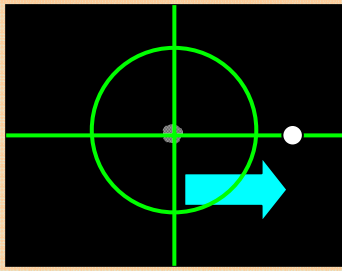

Changing settings

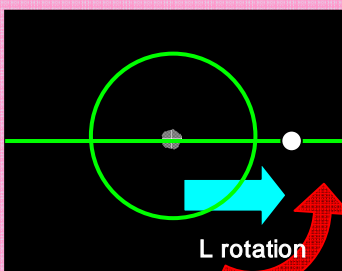

L rotation

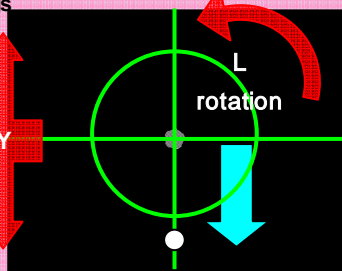

L rotation

Combination of:

Image rotation (L)

ROTATION L

+

Mirroring (X axis only)

MIRRORING X

Match the directions of operation and the spot movement in the screen => Greater ease of observation

3.7. DISPLAY

Setting display or non-display measurement value.



- 1) ON : Measurement result is displayed on the screen.
- 2) OFF : Measurement result is not displayed on the screen.

3.8. UNIT

Selecting a display unit.

Measurement result is sent and displayed in the specified unit.



- 1) deg : Unit is changed to degree.
- 2) min+sec : Unit is changed to minute and second.
- 3) mrad : Unit is changed to milliradian.

3.9. COM

Setting communication speed.

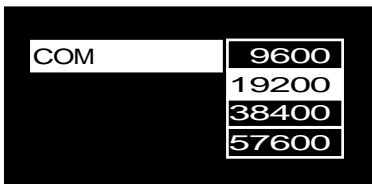

- 1) 9600 : Baud rate is set to 9600 bps.
- 2) 19200 : Baud rate is set to 19200 bps.
- 3) 38400 : Baud rate is set to 38400 bps.
- 4) 57600 : Baud rate is set to 57600 bps.

3.10. DATA OUT

Setting output condition.



- 1) STREAM : Output data per measurement in 1 to 1 style (max 200msec interval).
- 2) I/O : Output data per measurement when I/O HOLD is set to ON.

3.11. KEY LOCK

Invalid key input.

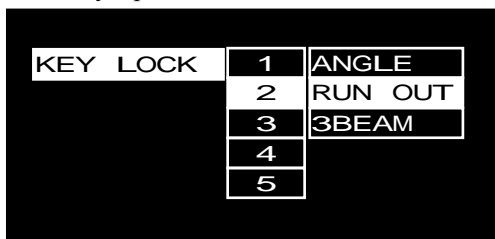

- 1) 1~5 : Select the file number for saving the current settings and loading at power on.
- 2) Mode selection: Select the measurement function to which the key lock applies. Measurement conditions must be set in advance.

Caution: At the factory default, save the calibration value matched to an autocollimator in the file 1.
Please note when overwrite on file 1, lost the factory default.

* To cancel the key lock mode, hold [↓] key down for 3 seconds or longer.

When the key lock mode is selected, the title at the upper left of the measurement screen will be shown in black against light blue background color.

3.12. REMOTE

Setting remote mode.

The remote mode allows external control via serial communication (control by I/O input will be disabled).

See 12.1 for the list of serial communication commands.

REMOTE	1	ANGLE
	2	RUN OUT
	3	3BEAM
	4	OFF
	5	

- 1)1~5 : Select the file number for saving the current settings and loading at power on.
 - 2) Mode selection: Select the measurement function to use while in remote control mode. Measurement conditions must be set in advance.
- When OFF is selected, current settings are saved with the remote mode canceled.

* To cancel the remote mode, hold [↑] key down for 3 seconds or longer or use the remote cancel command. When the remote mode is selected, the title at the upper left of the measurement screen will start with “*” and be shown in light blue color.

3.13. SAVE

Saving system setting data

SAVE	1
	2
	3
	4
	5

- 1)1~5 : Select the file number for saving the current system settings.

(Note)

- Default settings assuming the use of the Laser Auto Collimator are stored in FILE1 before shipment from the factory.
- Do not overwrite FILE1. Otherwise, all default settings will be lost.

4. Angle Measurement

4.1. SINGLE Measurement Basic Functions

Light spots are measured, one at a time, and the results are displayed along with an OK/NG decision.

Center of area: When several spots exist (up to 3), specify the spot number for measurement.

Luminance centroid: When several spots exist, the center of several spots is used as the detection point.

* When several spots exist, specify the label number of a single spot for measurement.

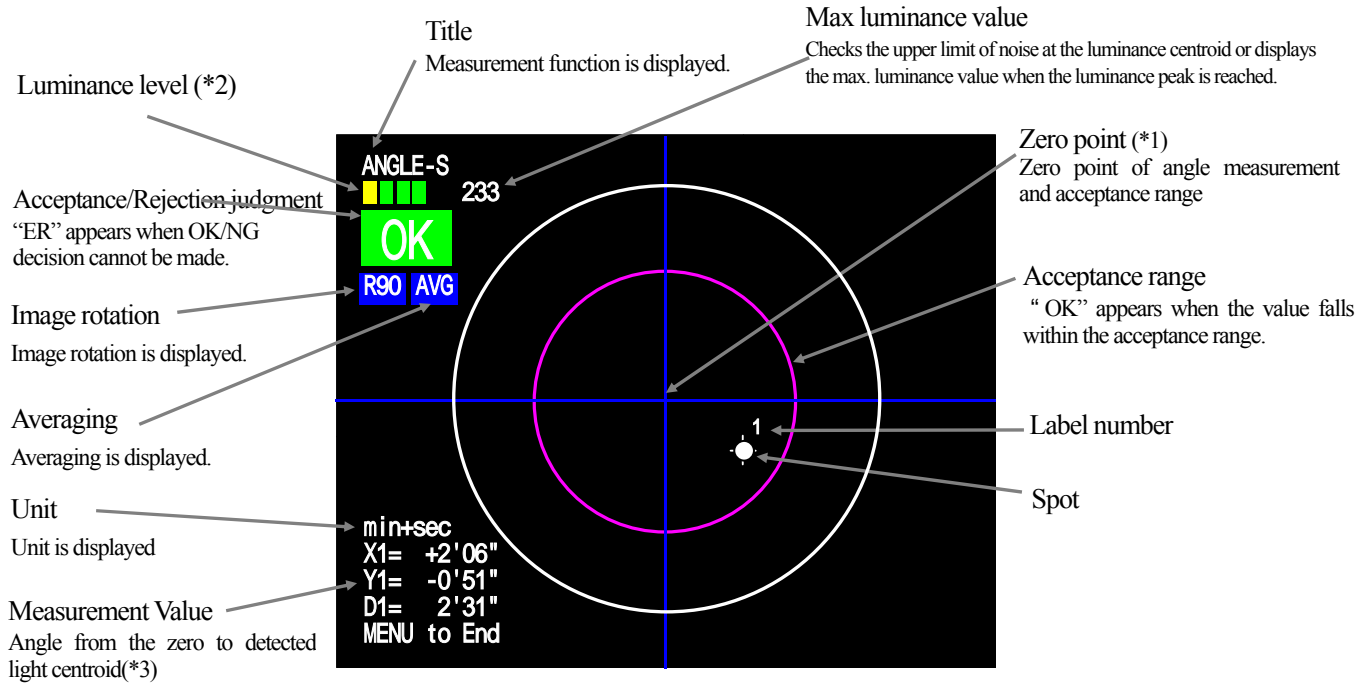

***1 Center of acceptance range (Zero point)**

Zero point of angle

See "5.3. ZERO SET" for details.

***2 Luminance Level**

Luminance of the detected light is indicated by the level bars. (See "4.1. Luminance Level Bar")

The displayed items vary by the measurement function (center of area, center of brightness, brightness peak).

***3 Measurement Value**





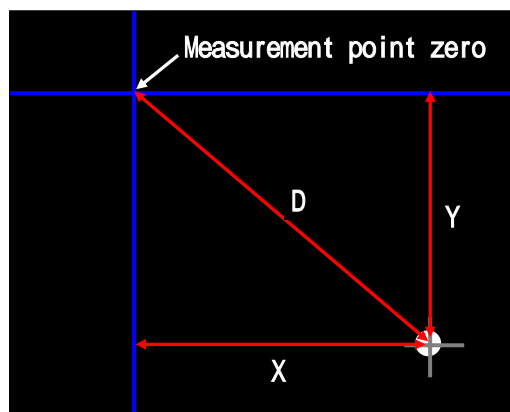

Measured values at the specified spot are displayed.

The numbers after X, Y, and D represent label numbers.

X, Y, and D each represents the angle from the center of tolerance(as shown below).



• Luminance Level Bar

No.	Bar Display	Color	Status	Content
1		Black	Under (Error)	Unmeasurable as the minimum brightness level is not reached: <ul style="list-style-type: none"> • BIN (Center of area): Threshold • GRAY(Center of brightness): NOISE level • PEAK (Brightness peak): Brightness of less than 30 See “5.5. MODE” for details about these levels.
2		Yellow	Low	Measurable but unstable due to low brightness.
3		Green	Good	Adequate brightness for measurement. (three green bars represent the best condition for measurement).
4		Green		
5		Green		
6		Y/G	High	Measurable but brightness is saturating. Center of brightness / Brightness peak : Yellow; Center of area : Green
7		Red	Over (Error)	Unmeasurable due to saturated pixels (pixels with level 254) Center of area : 32768 pixels or more Luminance centroid / Luminance peak : 3 pixel or more

4.2. MULTI (Relative) Measurement Basic Functions [MULTI R.]

Several spots (up to 3) are detected, and the results are displayed along with an OK/NG decision.

When several spots exist (up to 3), select spots to be evaluated (1 or all).

The measured values for a given spot are displayed along with relative angles between two spots.

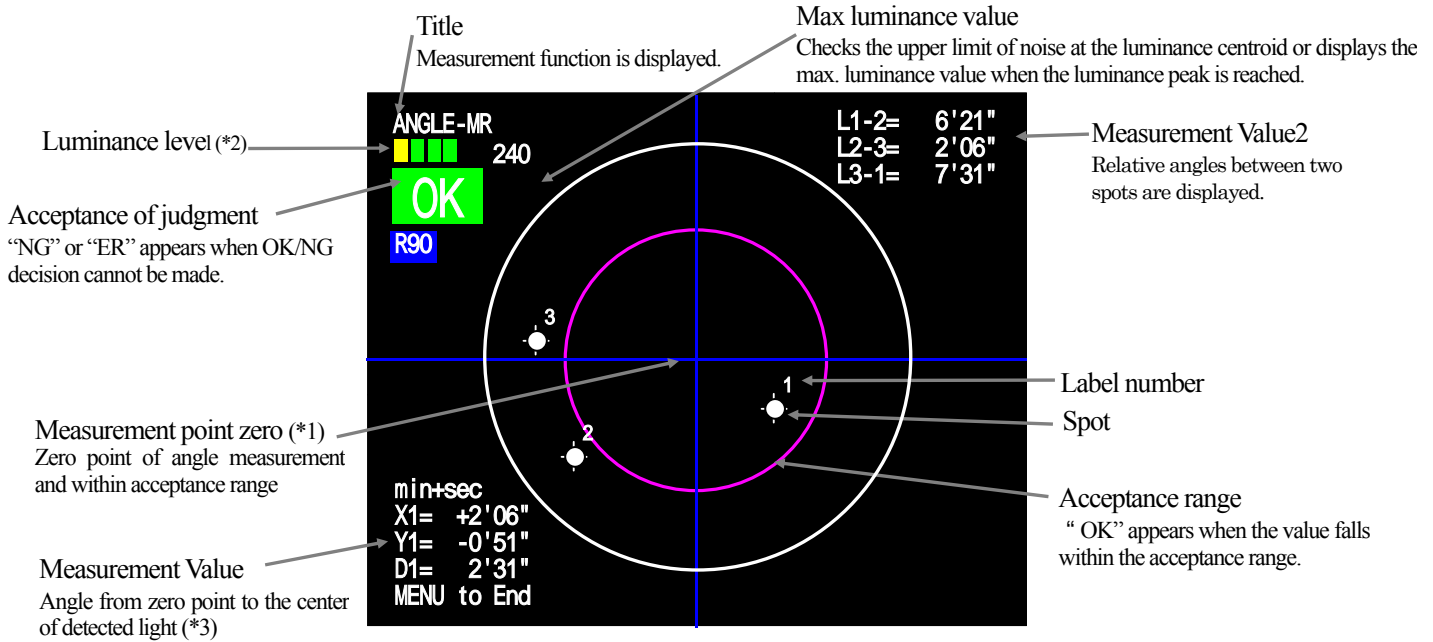

***1 Center of acceptance range**

Zero point of angle

See "5.3. ZERO SET" for details.

***2 Luminance Level**

Brightness of the detected light is indicated by the level bars. (See "4.1. Brightness Level Bar" for details.)

The displayed items vary by the measurement function (center of area, center of brightness).

***3 Measurement Value**

The measured values for a given spot are displayed.

The numbers after X, Y, and D represent label numbers.

Displays angle that from zero spot on the lower left of the screen.

Relative angles between two spots are displayed in the upper right of the screen.

L1-2 : Relative angle between Labels 1-2

L2-3 : Relative angle between Labels 2-3

L3-1 : Relative angle between Labels 3-1

Example of measurement : MULTI (Relative) Measurement (MULTI R.)

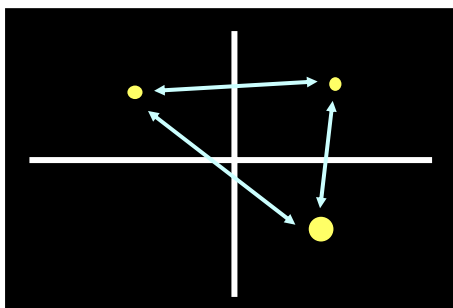

Angles between two spots are measured.

4.3. MULTI (Absolute) Measurement Basic Functions [MULTI A.]

Several spots (up to 3) are detected, and the results are displayed along with an OK/NG decision.

When several spots exist (up to 3), select spots to be evaluated (1 or all).

The measured values for all spots from zero point are displayed along with an OK/NG decision.

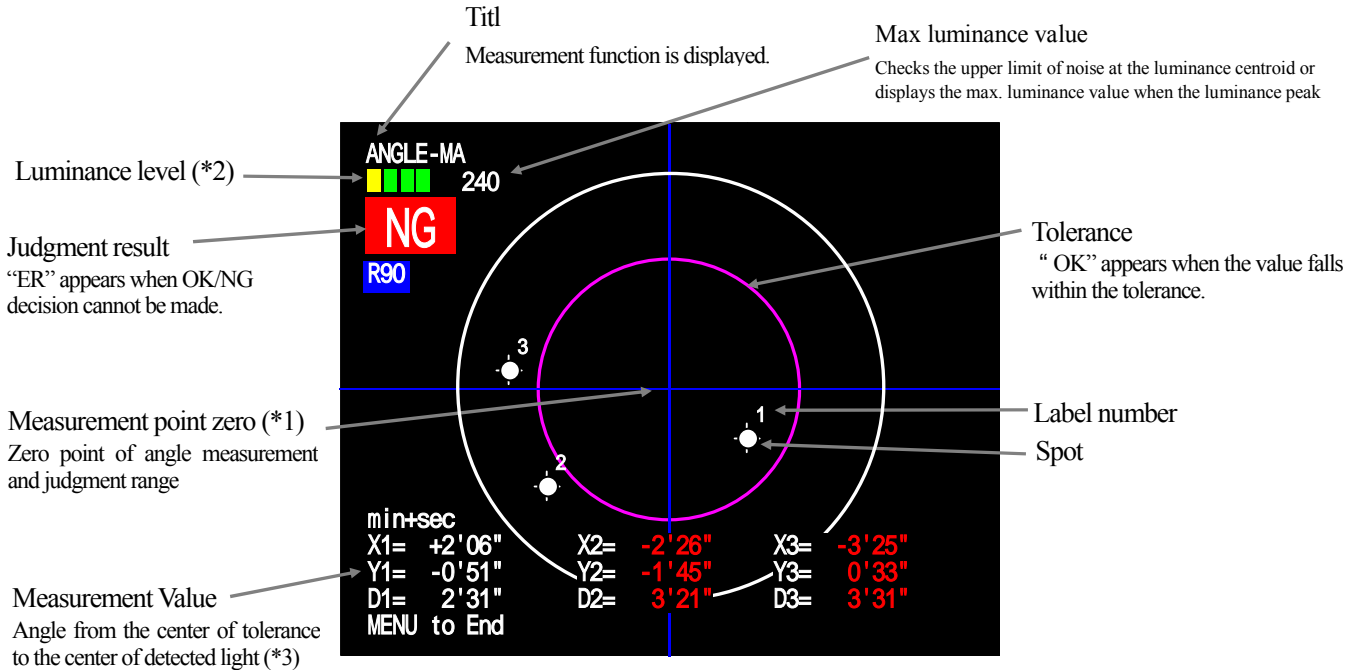

***1 Zero point**

Zero point of angle

See "5.3. ZERO SET" for details.

***2 Luminance Level**

Luminance of the detected light is indicated by the level bars. (See "4.1. Luminance Level Bar" for details.)

The displayed items vary by the measurement function (center of area, luminance centroid).

***3 Measurement Value**

Measured values for all spots are displayed.

The numbers after X, Y, and D represent label numbers.

Example of measurement : MULTI (Absolute) Measurement (MULTI A.)

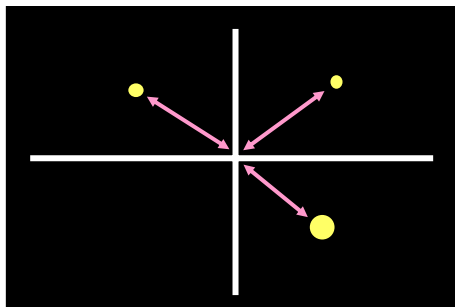

Angles from the reference point are displayed for all spots.

4.4. OFFSET TILT Measurement Basic Functions

This function is useful when measuring the initial angle followed by relative angle in reference to the initial position. Three types of decision are available. Judgment Offset function may be added to gain extra freedom of adjustment or inspection.

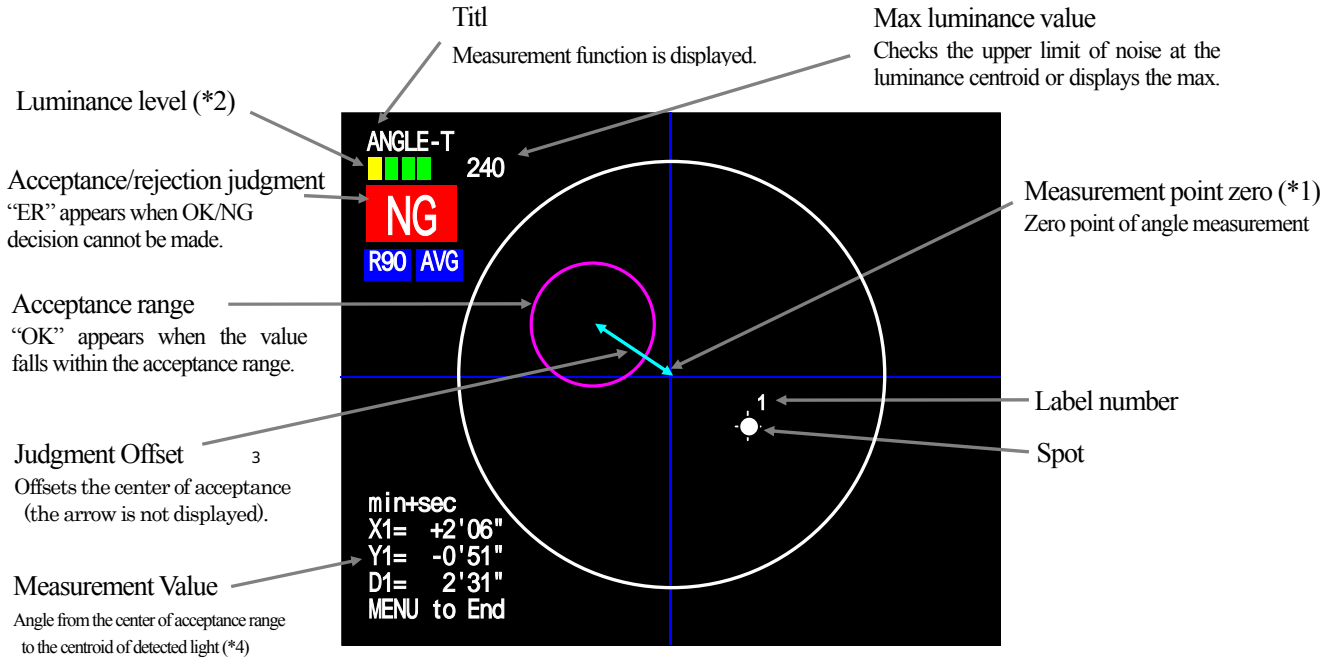

- *1 Measurement point zero**
Zero point of angle
See "5.3. ZERO" for details.
- *2 Luminance Level**
Luminance of the detected light is indicated by the level bars. (See "4.1. Brightness Level Bar")
The displayed items vary by the measurement function (center of area, luminance centroid, luminance peak).
- *3 Center of acceptance range**
Zero point of angle acceptance
See "5.3. ZERO SET" for details.
- *4 Judgment Offset**
When I/O IN_A is set to ON while in the OFFSET TILT mode, the decision type is switched to Judgment Offset.
See "5.8 TOLERANCE" for details.
- *5 Measurement Value**
Measured values for spots are displayed.
The numbers after X, Y, and D represent label numbers.

5. Angle Measurement Setting

5.1. Angle Measurement Usage

5.1.1. New measurement (Angle Measurement Setting)

Angle measurement setting is required before using the processing unit for the first time or whenever resetting of measurement conditions is necessary. Follow setting steps shown below and see the applicable sections (numbers written to the left) for details.

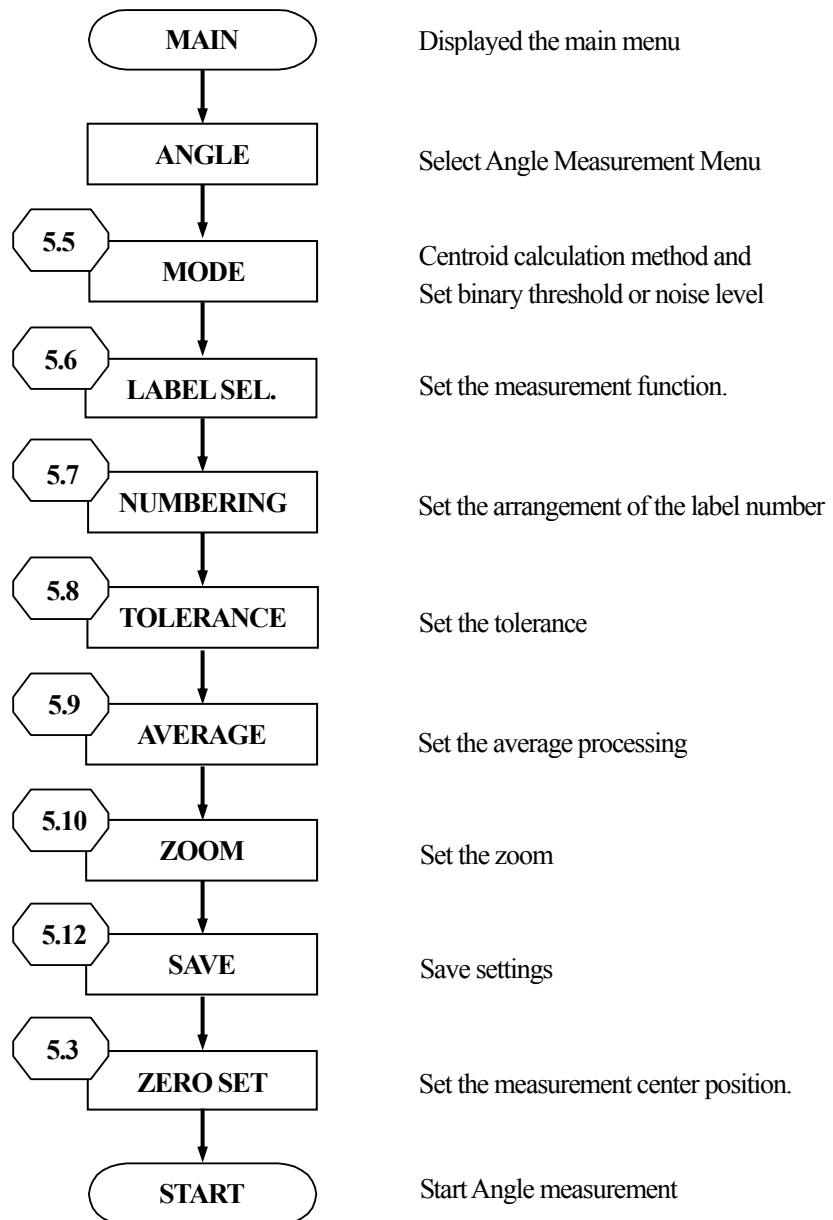

(Note)

- Default settings assuming the use of the Laser Autocollimator are stored in FILE1 before shipment from the factory. Load FILE1 when you wish to return to default settings.
- Do not overwrite FILE1. Otherwise, all default settings will be lost.
- At power on, the system will start with the last saved or loaded file number and mode of operation.

5.1.2 Measurement Using Saved Setting Data

This section applies to the measurement conditions that are set already.
 Follow steps shown below to perform measurement using existing data.
 At power on, the system will start with the last saved or loaded file number.
 See the applicable sections (numbers written to the left) for details.

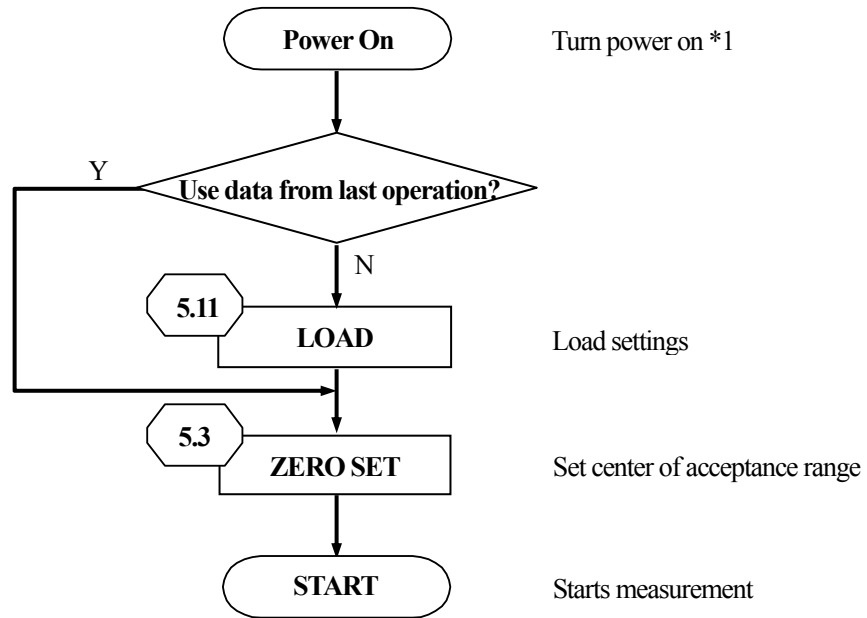

(Note)

- Default settings assuming the use of the Laser Auto Collimator are stored in FILE1 before shipment from the factory. Load FILE1 when you wish to return to default settings.
- Do not overwrite FILE1. Otherwise, all default settings will be lost.

***1 “Load ERROR!!” will appear when the saved data contain an error at power on.**

When this occurs, select OK in the memory initialization confirmation screen and start again. Angle calibration is required after memory initialization. See “10. ANGLE CALIBRATION” for details about angle calibration.

5.2. Setting Screen & Contents

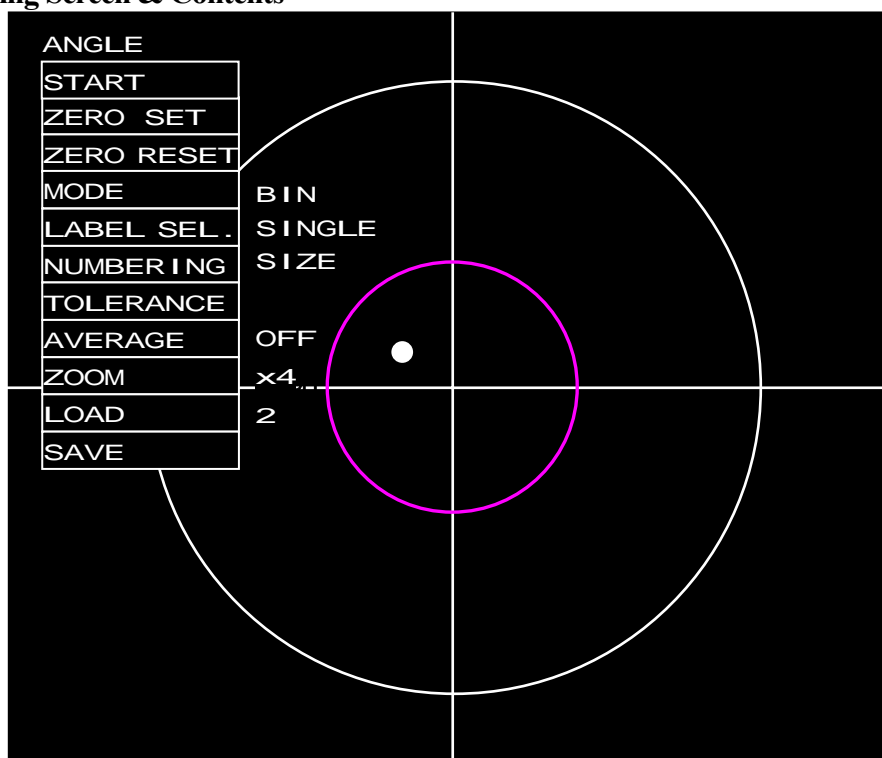

Setting Screen

Setting Items

Name	Content Description	Setting Value	Page
START	Start to measure the angle.	-	4
ZERO SET	Set the measurement Point Zero (Angle 0 deg). Measurement value on Measurement screen will be set to zero.	-	5.3
ZERO RESET	Set the zero point to the center of measurement area.	-	5.4
MODE	Set the method of the detection position calculation.	BIN / GRAY / BMAX	5.5
LABEL SEL.	Set the measurement function.	SINGLE MULTI R. MULTIA OFFSET/TILT	5.6
NUMBERING	Set the arrangement of the label number.	SIZE / ANGLE	5.7
TOLERANCE	Set the acceptance range.	D1 / X-Y / D2 OFFSET / OFF	5.8
AVERAGE	Set the average processing.	2 / 4 / 8 / OFF	5.9
ZOOM	Set the zoom.	OFF / x4 / x8 / x16	5.10
LOAD	Reading out setting data	1~5	5.11
SAVE	Saving setting data	1~5	5.12

5.3. ZERO SET

When setting up the measurement system, use the two-axis tilt stage (HB10) to move the light spot from the laser light source mechanically as close to the intersection of the reticle in the screen (preliminary alignment). Then, select "ZERO SET" in the setting screen. May cause change the centroid position at the center of area and luminance centroid of centroid estimation. (After change setting, please do again ZERO SET)

5.3.1 Setting the zero point

The center is to be a standard point of acceptance range(indicated by pink lines) at the zero point. The zero point and acceptance range can be shifted as needed within the range of measurement.

- 1) After angle calibration is completed, select [ZERO SET] and press [ENT] key.
- 2) Using a master substrate, etc, display a detected light that is to be a zero spot.
- 3) Press [ENT] key.

The center of the detected light is now defined as the zero point.

[ZERO SET] appears in the upper left corner of the screen.

The angle from the zero point is displayed in the lower left corner of the screen.

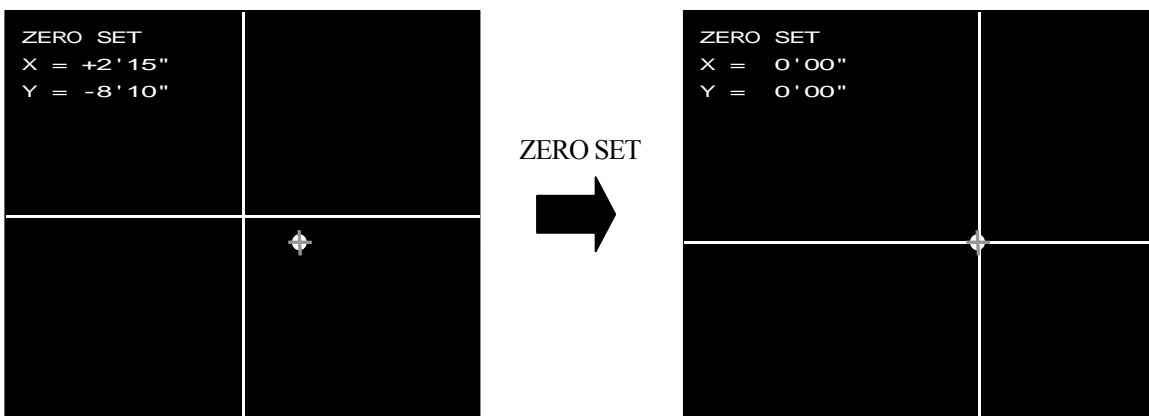

5.3.2 Definition of centers

A. Optical center

The optical center is the unique center of an optical system of the Laser Auto Collimator. It is adjusted to the center of the CCD built into the Laser Auto Collimator head.

The intersection of the green lines (displayed as the default point when setting the centers per 10.3.3) is the optical center.

B. Center of measurement range

The center of measurement range is the zero-point referenced in angle calibration.

The range is set per 10.3.2 after selecting Auto Collimator per 10.3.1. Normally, the center of measurement range should be aligned with the optical center (A) above.

C. Zero point

Should be zero point of measurement value. (Must be same spot zero point and center of acceptance when the single multi mode. Display blue cross-point

B. Must be same spot center of measurement range and zero point at the setting center of measurement range.

B. Can be shifted zero point with ZERO SET after setting center of measurement range.

D. Center of tolerance

Can be offset the center of tolerance (center of pink circle) from zero point at the only OFFSETTILT mode.

5.4. ZERO RESET

Set zero point to center of measurement range.



- 1) OK : Zero point is changed at the same position of center of measurement range.
- 2) CANCEL : Zero point is not change .

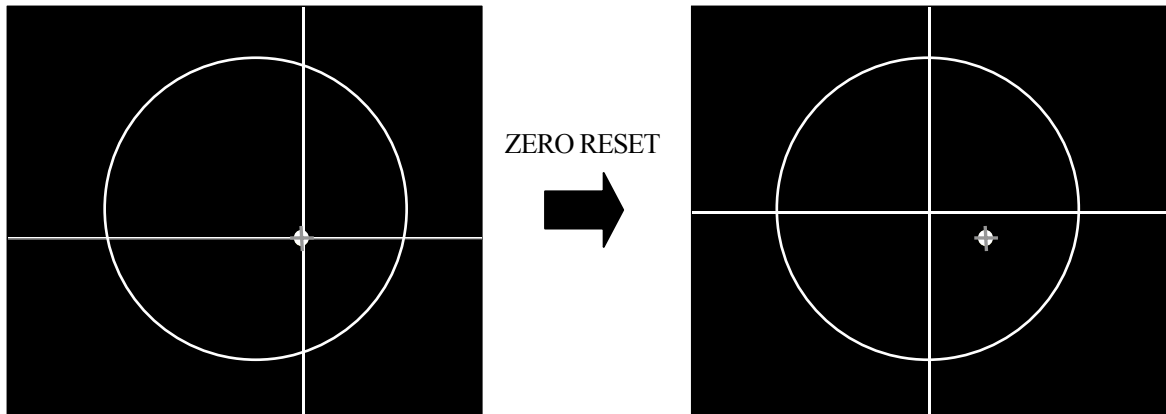

5.5. MODE

Set the method of the detection of the point.



- 1) Center of area (BIN)
The angle is determined by calculating the center of area based on the valid pixels having brightness higher than the threshold.
- 2) Luminance centroid (GRAY)
The angle is determined by calculating the weighted luminance centroid based on the valid pixels having luminance higher than the defined noise level.
- 3) Luminance peak (PEAK)
The maximum luminance is calculated and the angle is determined according to the position of the maximum brightness.

(Note)

Luminance peak applies to single spot measurement only.

The position (angle) of the detected light can be calculated in three ways, the center of area (BIN) and luminance centroid (GRAY) and the luminance peak(PEAK).

(* Objects characterized by scattering light cannot be measured.)

Recommended mode by the purpose

- Center of area (BIN) → Mirrors, beam splitters, etc
(Objects of measurement characterized by direct reflection)
- Luminance Centroid (GRAY) → Objective lenses, etc
(Objects of measurement characterized by strained reflection)
- Luminance peak (PEAK) → Objective lenses, edge surface etc
(Objects of measurement characterized by strained reflection)

Center of area measurement

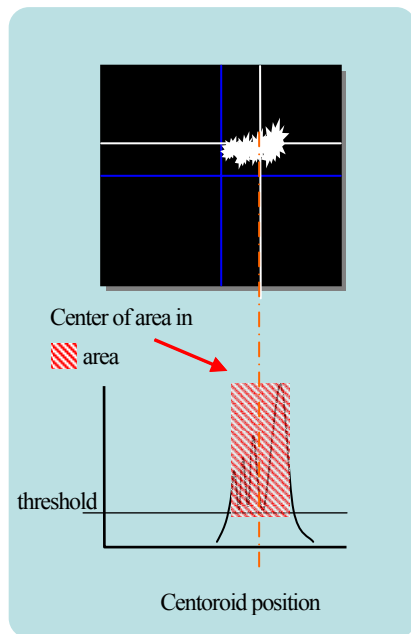

Luminance centroid measurement

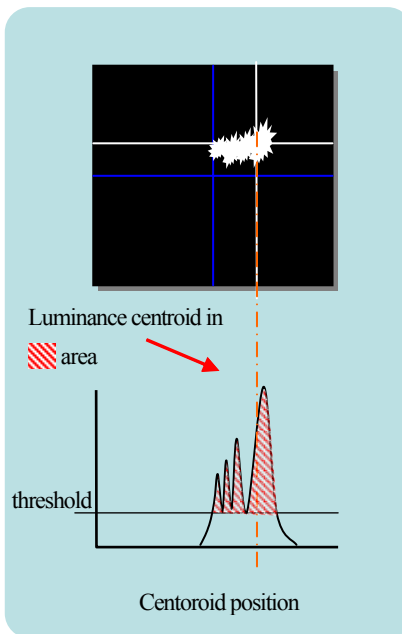

Luminance peak measurement

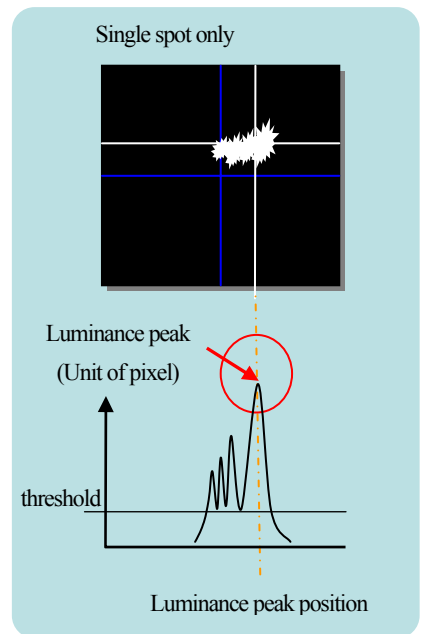

>Mirror



>Glass

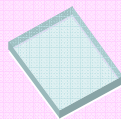

>Lens (With plane part)



The above shows results of a single spot measurement.

5.5.1 Center of area(BIN)

- 1) Select "MODE" on the Setting screen and press [ENT] Key.
- 2) Select "BIN" and press [ENT] Key.

The image to be processed is displayed in white.

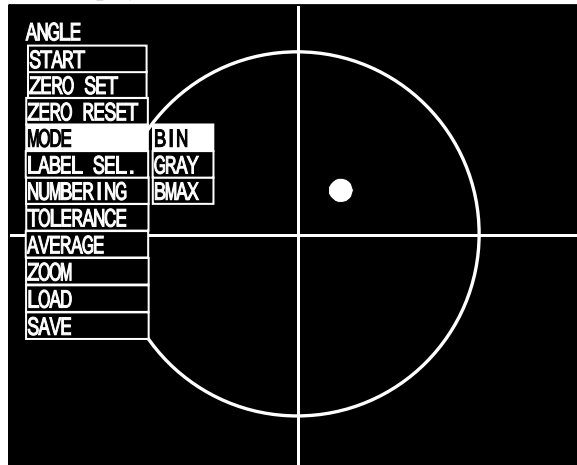

- 3) Adjust levels of binary threshold with [↑][↓] Key. When the adjustment is done, press [ENT] Key.
If you wish to cancel it, press [MENU/RUN] Key.

Press [↑][↓] Keys to change the value.

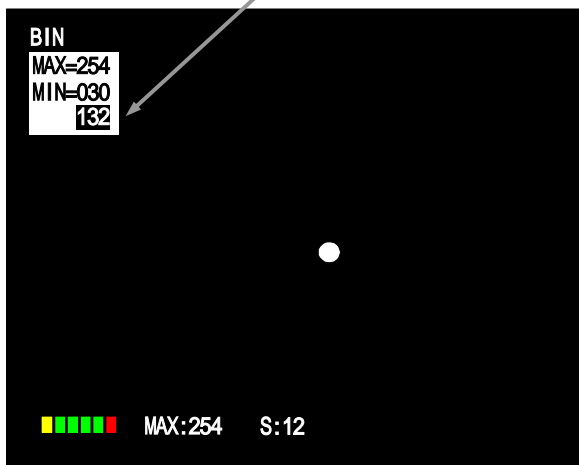

Before

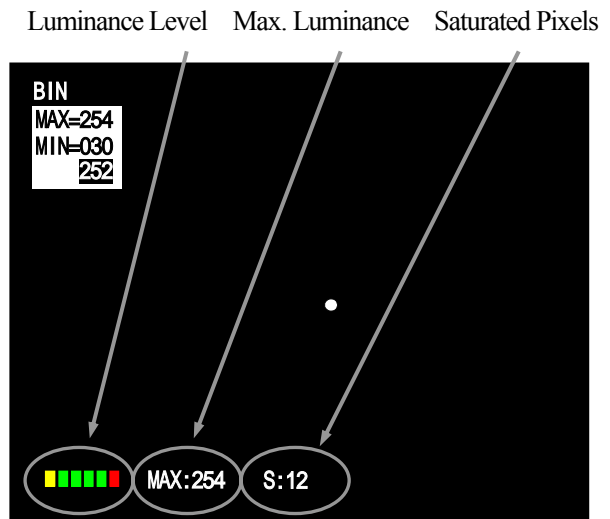

After change

• Important notes about setting

When more than one detected light is in view for threshold setting, the light dots must be adjusted as shown below so that there is only one dot.

- 1: Lower the LD volume of the Laser Auto Collimator.
- 2: Focus the beam diameter of the Laser Auto Collimator with the pinhole plate so that light lands on the desired measurement point.
- 3: Increase the shutter speed of the Laser Auto Collimator.
- 4: Increase the binary threshold.

• About binarization

Binarization refers to setting the threshold using a gradation level between 30 and 254. Pixels over the threshold are considered valid. An error is returned when the number of valid pixels exceeds 32767.

• Luminance Level

Luminance of the detected light is indicated by the level bars. (See "4.1. Luminance Level Bar")

The displayed items vary by the measurement function (center of area, Luminance centroid, Luminance Peak).

5.5.2 Luminance centroid(GRAY)

- 1) Select "MODE" on the Setting screen, and press [ENT] Key.
 - 2) Select "GRAY", and press [ENT] Key.
 - 3) Select "NOIZE", "NCHECK HIGH" or "NCHECK LOW", "NCHECK OFF", and press [ENT] Key.
- The image to be processed is displayed in white.

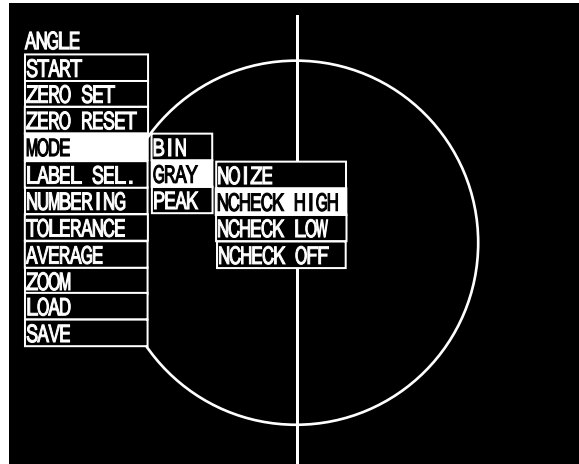

GRAY selection screen

- a) NOIZE : Set the noise level (minimum level)
- b) NCHECK HIGH : Set the upper limit of noise (NG if measured value exceeds this level and is 254 or less).
- c) NCHECK LOW : Set the lower limit of noise (NG if measured value falls below this level and is equal to the noise level or higher).
- d) NCHECK OFF : Luminance level check is not performed.

Luminance level check

Noise level : N , Lower limit : L , Upper limit : H

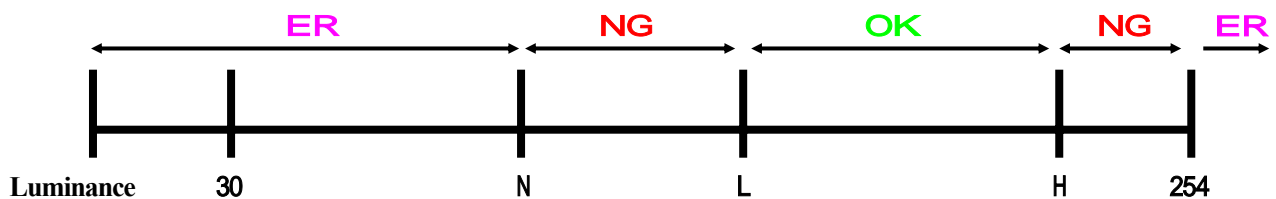

The following relation applies to N, L, and H when luminance level check is performed:

$$\text{Luminance } 30 \leq N < L < H \leq 254$$

If N is greater than L, N is changed to a value smaller than L.

The following applies to N when luminance level check is not performed:

$$\text{Luminance } 30 \leq N \leq 254$$

- 4) Adjust noise level with [↑][↓] Key. When the adjustment is done, press [ENT] Key.
Press [MENU] Key if cancellation.

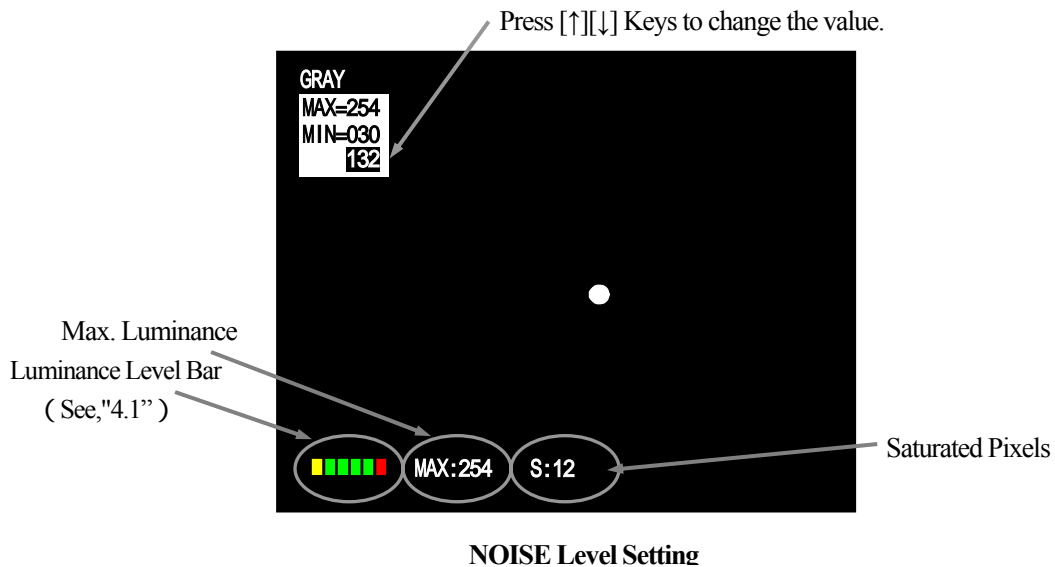

- Important notes about setting

Adjust the laser output (volume) and shutter speed of the Laser Auto Collimator so that only the measurable detected light is measured.

An error is returned (unmeasurable) when the number of saturated pixels (luminance level 254) is 2 or more but the measured value is displayed. (For best results, work with settings that lead to green bars.)

- About a noise level

A noise level refers to the threshold defined with a gradation level between 30 and 254. Pixels under the defined noise level are excluded from measurement or calculation.

- Luminance Level

Indicates luminance of detected light with level bar. (See "4.1. Luminance Level Bar")

Display level varies for each measurement function (center of area, luminance centroid, luminance peak).

5.5.3 Luminance Peak(PEAK)

- 1) Select "MODE", and press [ENT] Key.
- 2) Select "PEAK", and press [ENT] Key.

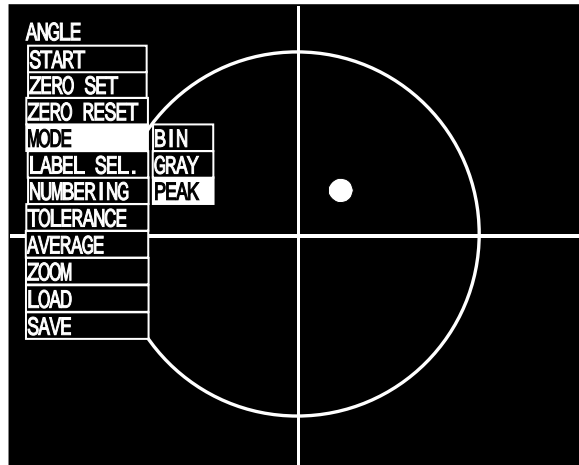

PEAK selection screen

Detect the position the maximum luminance.

The center of area is detected when the maximum luminance extends over several pixels continuously. (*1)

An error is returned if the maximum luminance extends over several pixels discontinuously. (*2)

(Note)

This applies to single-spot measurements only.

An error will result in multi-spot measurements.

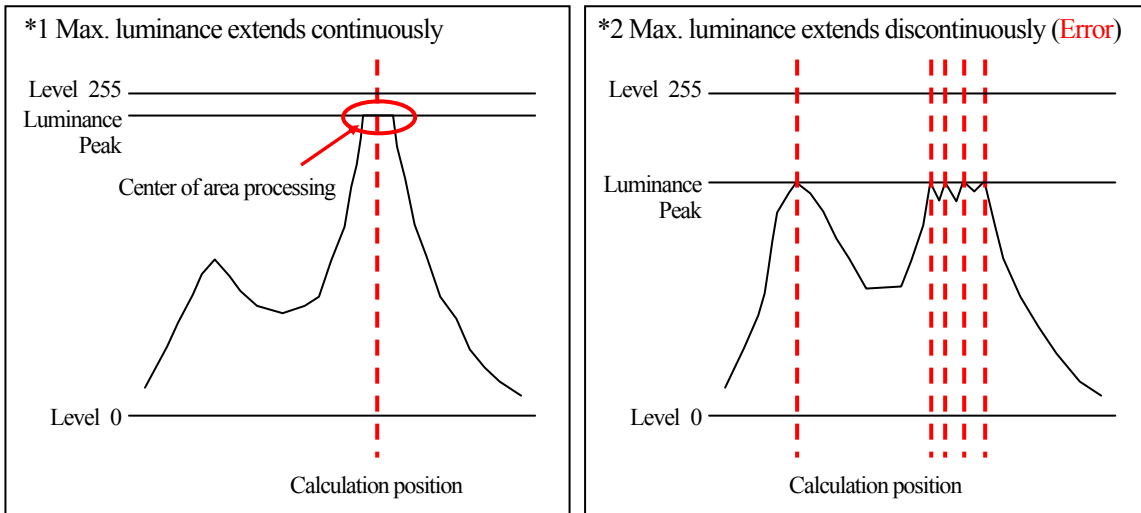

5.6. LABEL SEL.

Set the measurement function.



- 1) SINGLE : Perform single-spot measurement.
Measure the angle of a spot (single spot) from the center of measurement.
- 2) OFFSETTILT : Perform offset tilt measurement by single-spot measurement.
Measure the angle of a spot (single spot) from the center of measurement.
Change an acceptance range or an offset range by I/O input.
- 3) MULTI R. : Perform multi-spot (relative) measurement.
Measure the relative angles between all spots (up to 3 spots).
- 4) MULTI A. : Perform multi-spot (absolute) measurement.
Measure the angles of all spots (up to 3 spots) from the center of measurement.

5.6.1 Single Spot Measurement (SINGLE)

Single-spot measurement function is used when a single spot needs to be measured.
When several spots exist, specify the label number of a single spot for measurement.

- 1) Select " LABEL SEL.", and press [ENT] Key.
- 2) Select " SINGLE", and press [ENT] Key.
- 3) Select a label number from "1~3", and press [ENT] key.
When cancelation, press [MENU] Key.



- a) 1 : The spot having label number 1 is chosen for measurement.
- b) 2 : The spot having label number 2 is chosen for measurement.
- c) 3 : The spot having label number 3 is chosen for measurement.

* An error is returned when the selected label number of the spot is not reached.

5.6.2 OFFSETTILT Measurement (OFFSETTILT)

It starts to perform absolutely measures from zero point, then perform static relative measurement as absolutely measurement point is to be zero point.

- 1) Select " LABEL SEL." , and press [ENT] Key.
- 2) Select " OFFSETTILT", and press [ENT] Key.
- 3) Select "D1/D1" "D1/D2" or "D1/X-Y" from the Setting screen, and press [ENT] key.

When cancelation, press [MENU] Key.

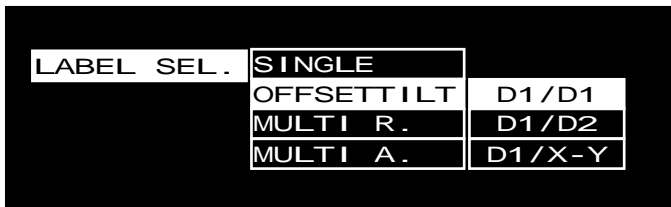

- a) D1/D1 : The circle (D1) is used for absolute measurement and relative measurement .
- b) D1/D2 : Using circle (D1) acceptance range for absolute measurement, and circle (D2) acceptance range is for relative measurement.
- c) D1/X-Y : Acceptance range of circle (D1) is for absolute measurement, and square (X-Y) is for relative measurement.

Example of use : Inspection of optical pickup actuators

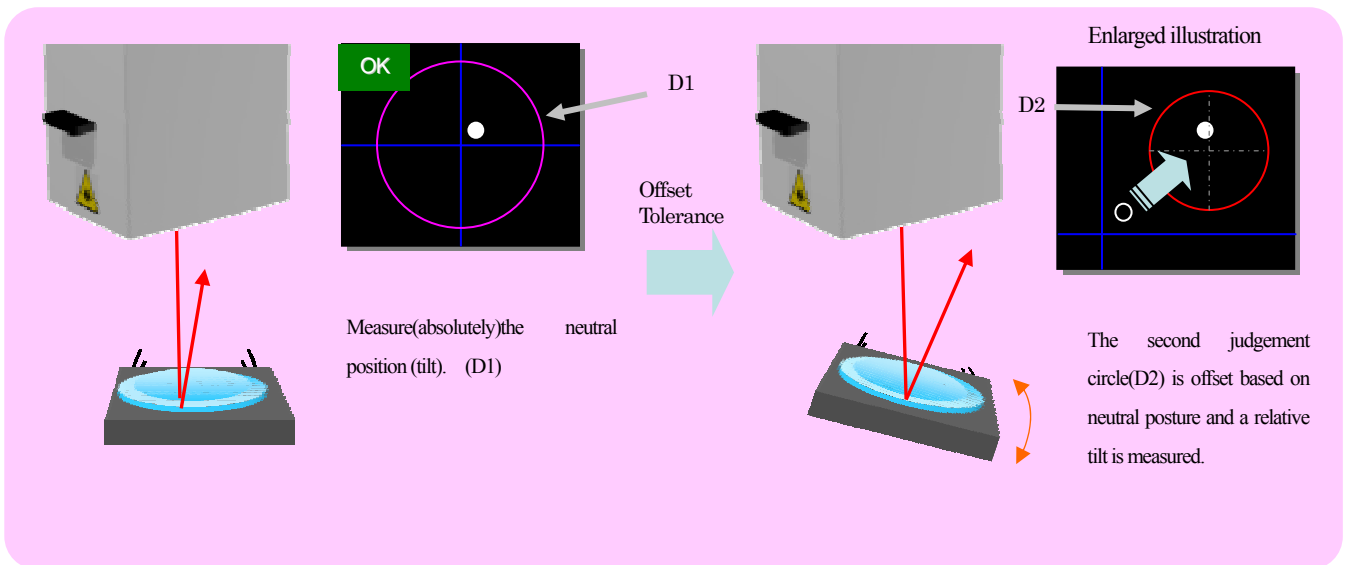

5.6.3 MULTI Relativity Measurement (MULTI R.)

Multi-spot (relative) measurement function is used to perform relative measurement (angles between spots).
A relative measurement determines the angle between two spots.

- 1) Select "LABEL SEL.", press [ENT] Key.
 - 2) Select "MULTI R.", press [ENT] Key.
 - 3) Select a spot from "1~3, ALL", and press [ENT] key.
- When cancelation, press [MENU] Key.



- a) 1 : The label number 1 is judged.
- b) 2 : The label number 2 is judged.
- c) 3 : The label number 3 is judged.
- d) ALL : All label numbers are judged. NG is returned when one of the spots falls outside of the tolerance range.

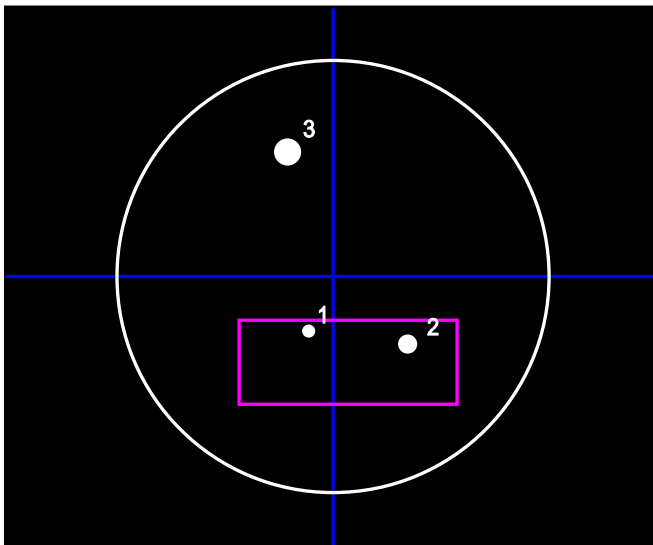

- EX1 : **OK** if label number 1 is judged.
 EX2 : **OK** if label number 2 is judged.
 EX3 : **NG** if label number 3 is judged.
 EX4 : **NG** if all spots are judged.

The angle of the specified spot from the center of acceptance range is displayed (or the angle of the spot with label number 1 if all spots are chosen for tolerance).

* An error is returned when the selected label number of the spot is not reached. No error is returned when ALL is selected and at least one of the spots meets the label number.

5.6.4 MULTI Absolute Measurement (MULTIA.)

In case of absolutely measurement (angle from center), use MULTI Absolute Measurement function.
The angles from the center of acceptance range are displayed for all spots (up to 3 spots in total).

- 1) Select "LABEL SEL.", and press [ENT] Key.
- 2) Select "MULTIA.", and press [ENT] Key.
- 3) Select a spot from "1~3, ALL", and pres [ENT] key.

When cancellation, press [MENU] Key.



- a) 1 : The label number 1 is judged.
- b) 2 : The label number 2 is judged.
- c) 3 : The label number 3 is judged.
- d) ALL : All label numbers are judged. NG is returned when one of the spots falls outside of the tolerance range.

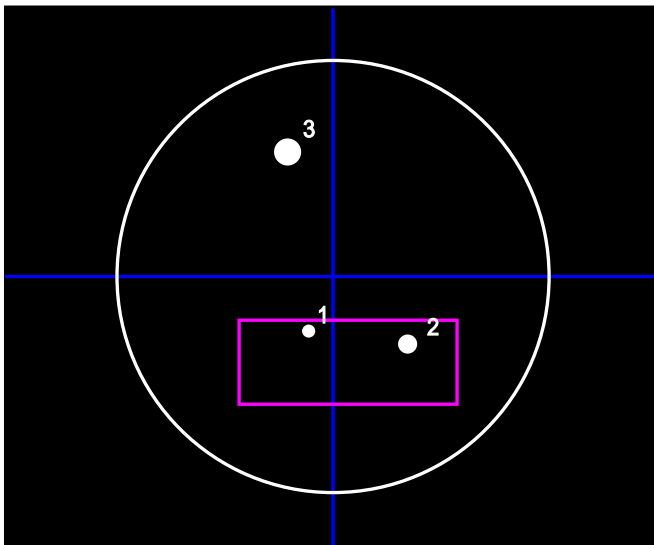

EX1 : **OK** if label number 1 is judged.
 EX2 : **OK** if label number 2 is judged.
 EX3 : **NG** if label number 3 is judged.
 EX4 : **NG** if all label numbers are judged.

* An error is returned when the selected label number of the spot is not reached. No error is returned when ALL is selected and at least one of the spots meets the label number.

5.7. NUMBERING

The arrangement of the label number is set.



- 1) SIZE : Spots are numbered starting with the spot having the largest area (in the descending order of area).
- 2) ANGLE : Spots are numbered starting with the spot having the largest angle from the center of measurement (in the ascending order of angle).

Ex1) SIZE

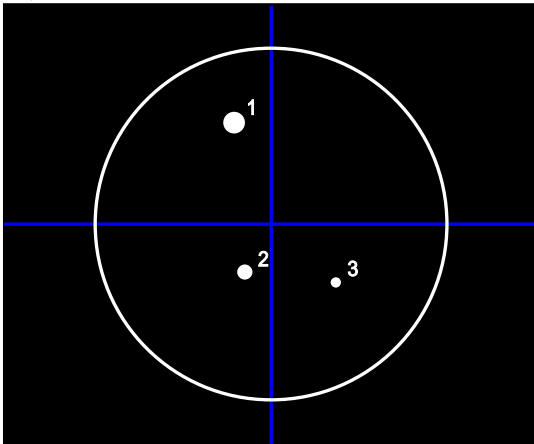

Ex2) ANGLE

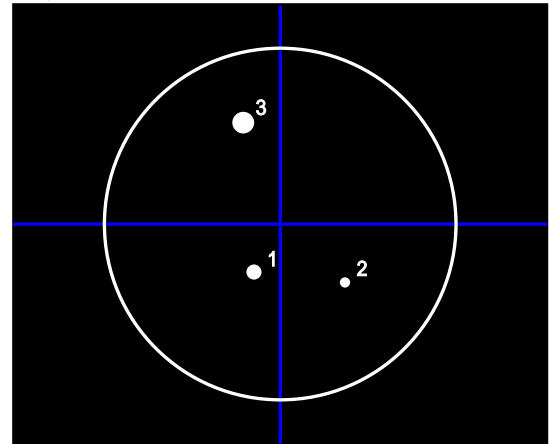

5.8. TOLERANCE

Set the tolerance.



- 1) D1 : Set the circle for the acceptance range.
Set the radius from the center of measurement.
- 2) X-Y : Set the square for the acceptance range.
Set X and Y from the center of acceptance.
- 3) D2 : Set the circle for the tolerance for Relativity OFFSETTILT measurement.
Set the radius from the center of measurement.
- 4) OFFSET : Set the offset for the tolerance for Relativity OFFSETTILT measurement.
Set the offset angle from the center of measurement.
- 5) OFF : Not work.

When set the circle (D1)

Enter the absolute value of the judgment angle with [↑][↓][ENT] Keys. The cursor moves to the next higher digit each time [ENT] key is pressed. The change is finalized when the highest digit is set.

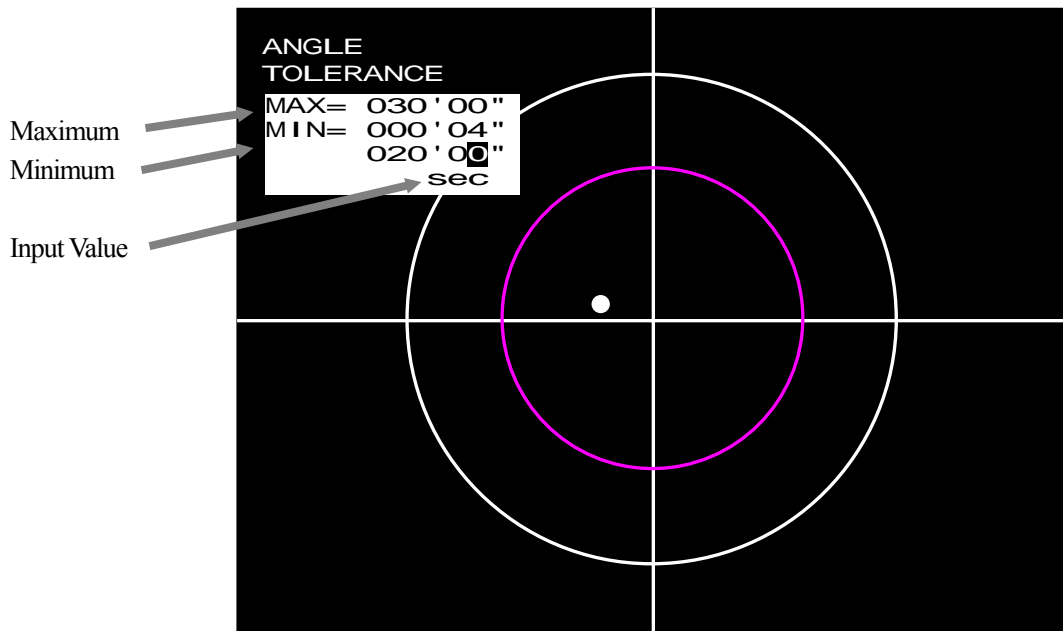

Setting screen

When set the square (X-Y)

Select XL (Left), XH (Right), YH (Upper), YL (Bottom) that means the tolerance of square, and input the Judgment angle.

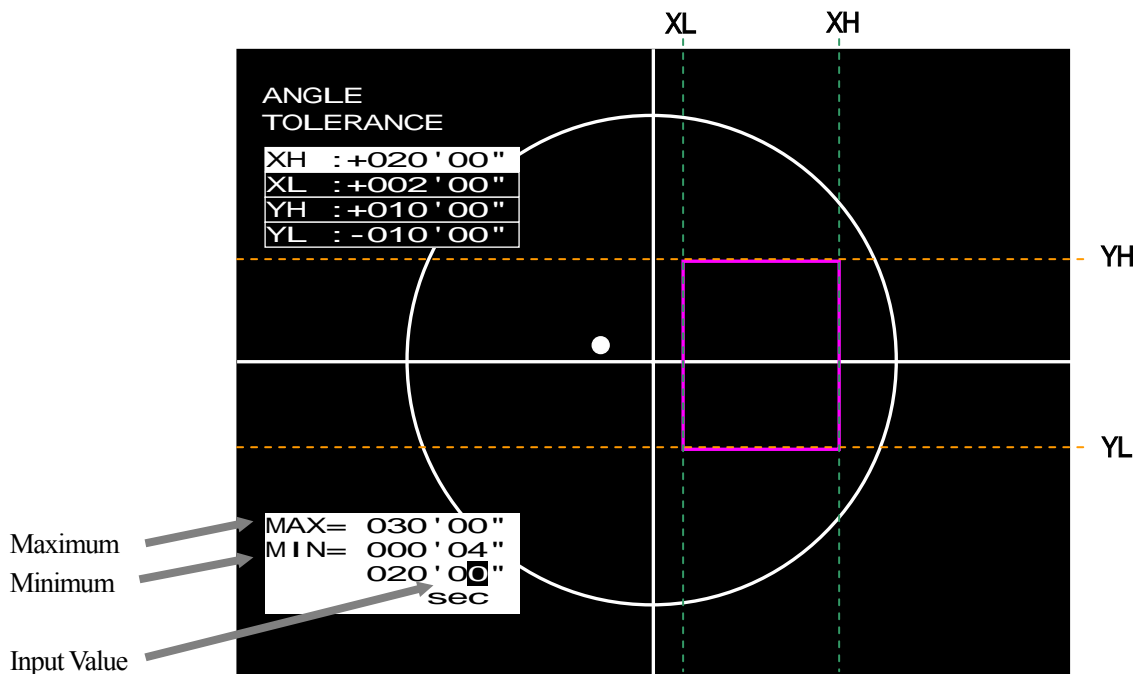

• Offset setting

Select X or Y at a time and enter the angle.

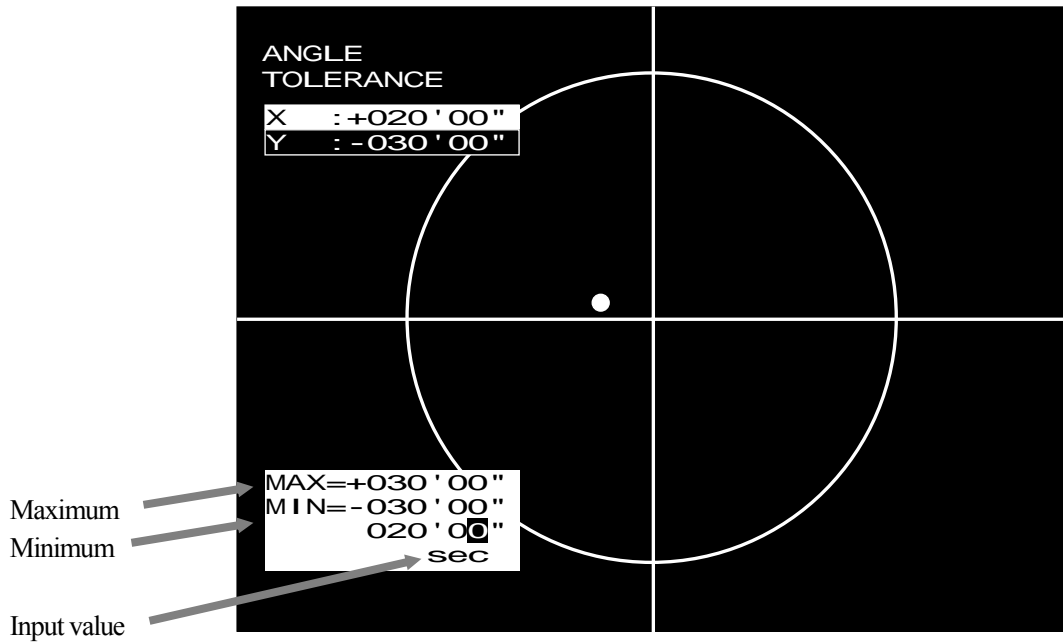

Ex) Offset

Offsetting the center of judgment from the center of measurement (intersection of the blue reticle) in the specified direction (X, Y).

Angle Measurement (OFFSETTILT D1→D1)

Absolute Measurement (D1 Judgment & Display)

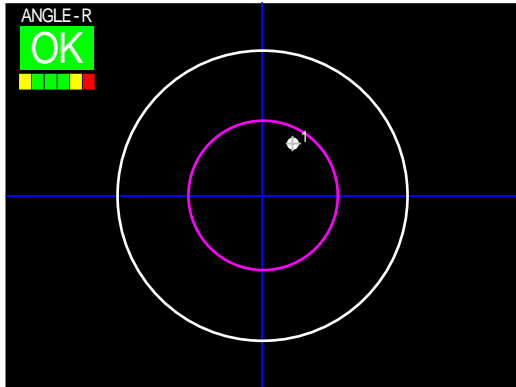

Relative Measurement (D1 Judgment & Display)

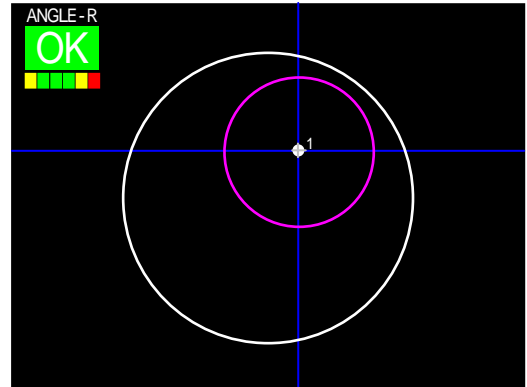

Relative Measurement and Offset

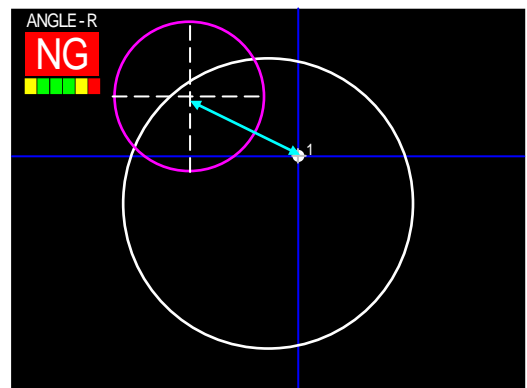

( Offset)

5.9. AVERAGE

Set the average processing.

Averaging applies only to the specified label number in single-spot measurement.



- 1) 2 : Average results from 2 measurements.
- 2) 4 : Average results from 4 measurements.
- 3) 8 : Average results from 8 measurements.
- 4) OFF : Averaging is not performed.

Averaging is performed by calculating the moving average from continuous measurements.

* When a measurement error is returned, the count of continuous measurements is reset to 1.

Example : Average of 8 measurements

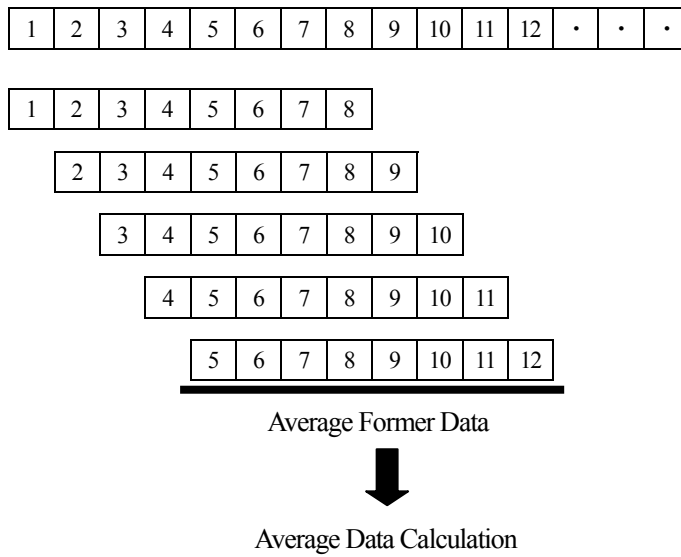

5.10. ZOOM

The zoom function can be turned on or off as shown below.

The zoom display is indicated by a yellow rectangle according to the zoom specification.

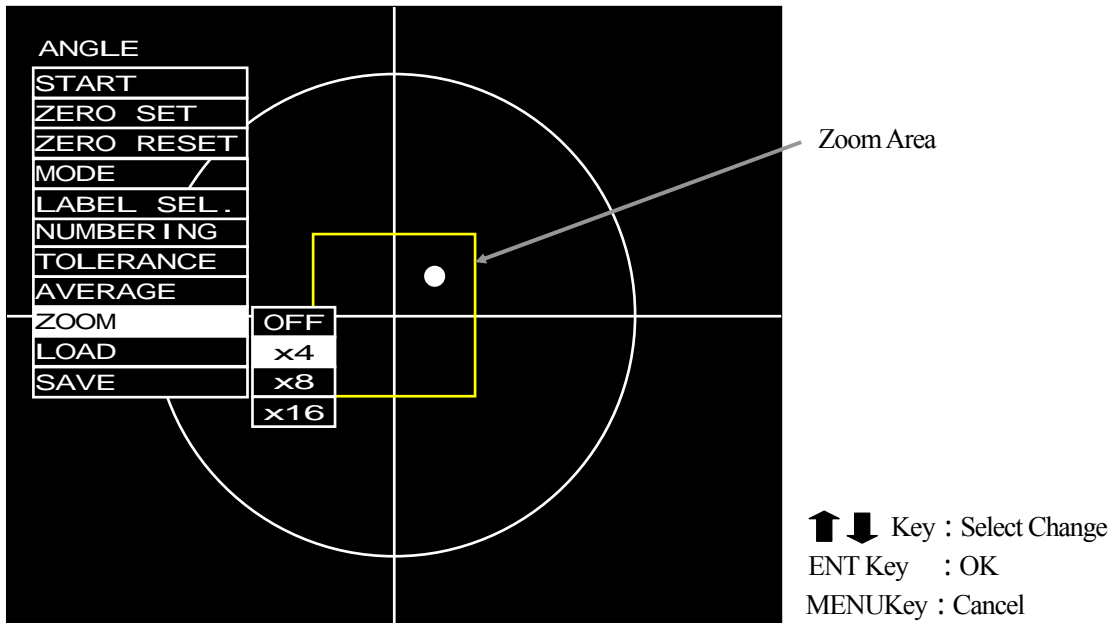

- 1) OFF : Zoom display is not performed.
- 2) x4 : X4 zoom display.
- 3) x8 : X8 zoom display.
- 4) x16 : X16 zoom display.

When you are moving toward the center of tolerance, the view of the judgment range may be very small for easy inspection of the central area.

When zoom display is specified, the display is zoomed automatically when the spot enters the zoom area.

- “ZOOM” appears in the monitor and the detected light disappears while the enlarged view is displayed (only the crossline is visible).
- An judgment range falling outside of the enlarged view area will not be displayed.
- When “AREA” is set to “X-Y” the view will be enlarged about the center of the rectangle.

Ex) Circle

1) Normal

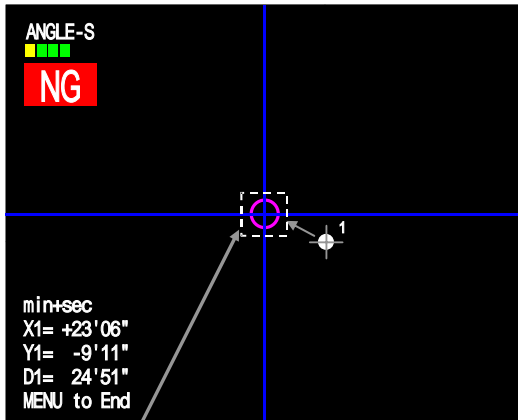

The zoom area is not shown in the screen.

2) Zoom

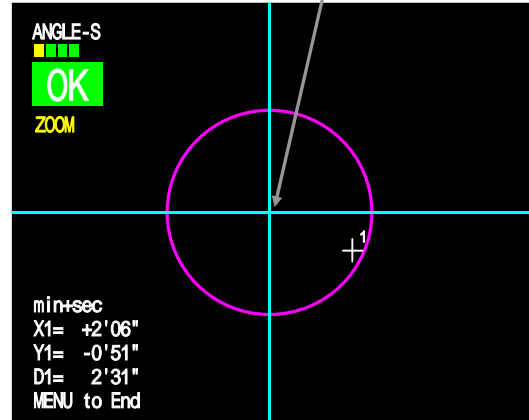

Ex) X-Y

1) Normal

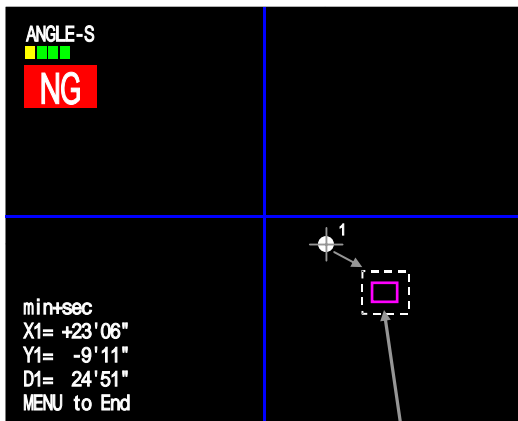

The zoom area is not shown in the screen.

2) Zoom

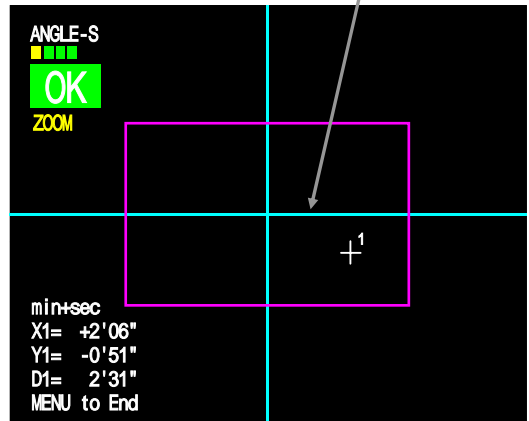

* The area for X16 zoom display is about 0.06 times the measurement range.

(Ex) 0.5-deg range Laser Auto Collimator

$$0.5 \times 0.06 = 0.03 \text{ deg}$$

The view will be enlarged about the center of tolerance when the value falls between ± 0.03 deg.

5.11. LOAD

Reading out setting data

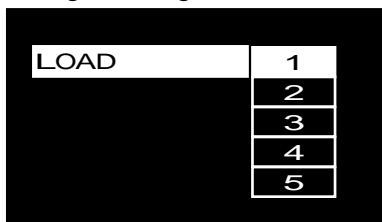

- 1) 1~5 : Load data from the selected number.
 An error is returned when no data have been saved under the selected number.

(Note)

- **Default settings assuming the use of the Laser Auto Collimator are stored in FILE1 before shipment from the factory.**
- **Load FILE1 when you wish to return to default settings.**

* Each file contains angle calibration data in addition to the conditions of measurement.
 Measurement conditions can be saved for up to five auto collimators having different ranges of measurement.

5.12. SAVE

Saving setting data

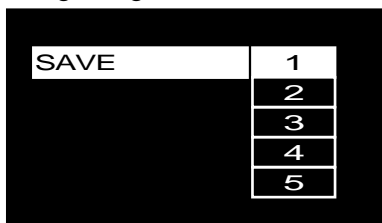

- 1) 1~5 : Angle measurement conditions and system data are saved under the selected number.

(Note)

- **Default settings assuming the use of the Laser Auto Collimator are stored in FILE1 before shipment from the factory.**

* Each file contains angle calibration data in addition to the conditions of measurement.
 Measurement conditions can be saved for up to five auto collimators having different ranges of measurement.

6. Runout Measurement

6.1. Runout Measurement Basic Functions

The runout measurement function may be used to measure the surface runout and axial tilt of optical disks, precision motors, etc.

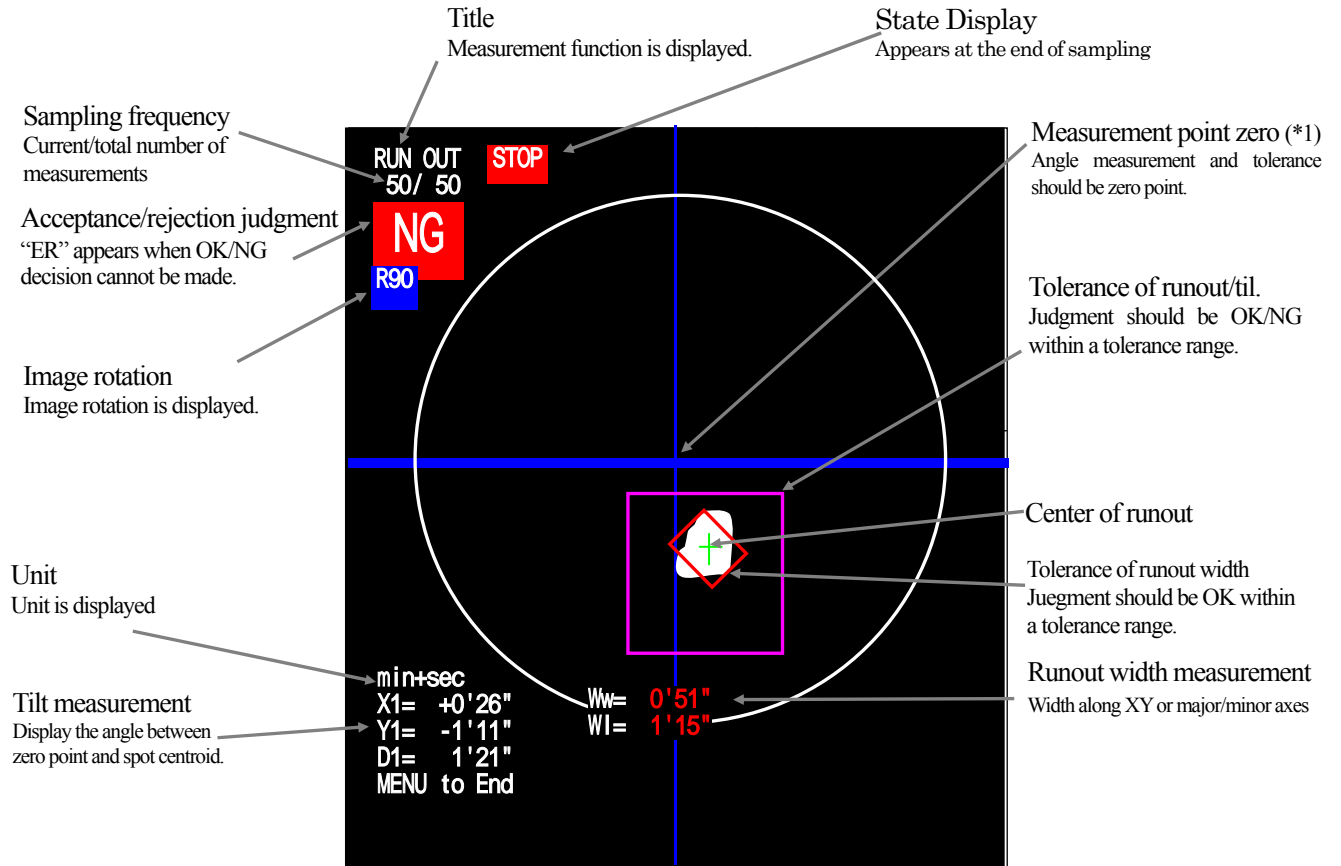

*1 Zero Point

Zero point of the angle

See "7.3. ZERO SET" for details.

7. Runout Measurement Setting

7.1. Runout Measurement Usage

7.1.1 New measurement (Runout MeasurementSetting)

Runout measurement setting is required before using the processing unit for the first time or whenever resetting of measurement conditions is necessary.

Follow setting steps shown below and see the applicable sections (numbers written to the left) for details.

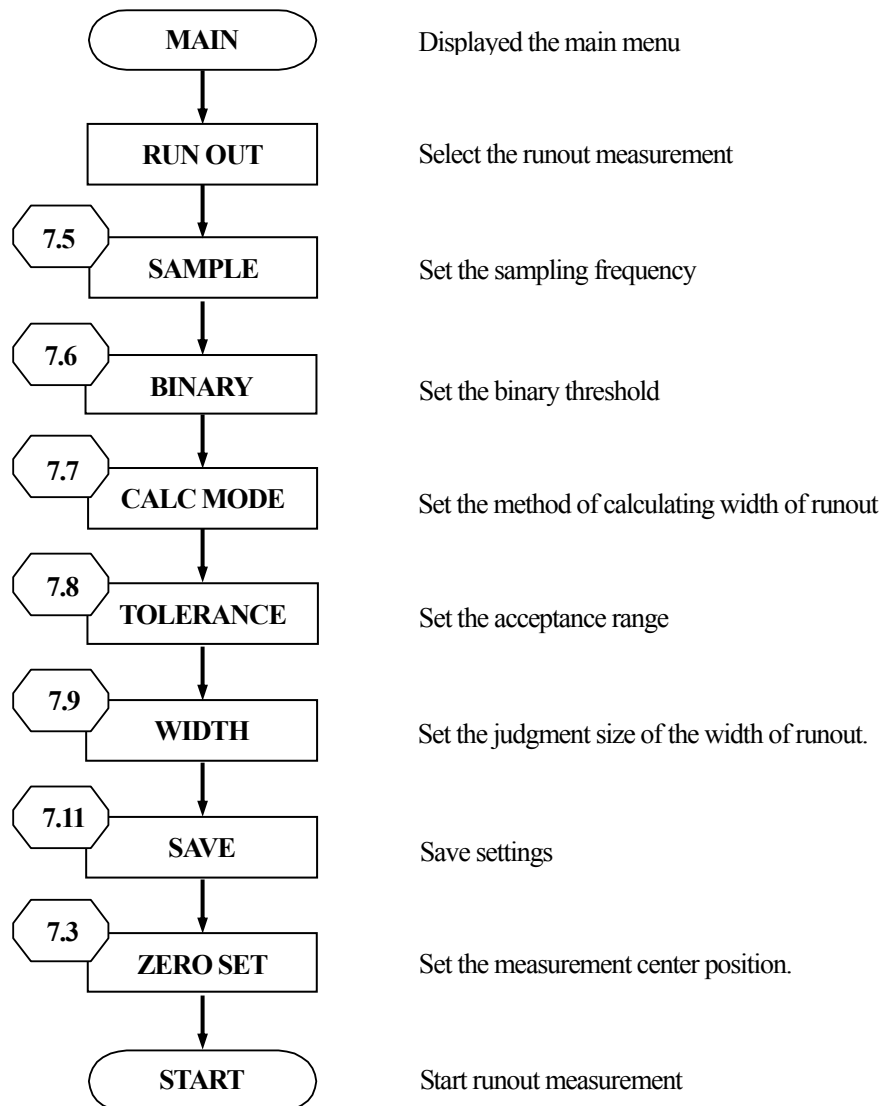

(Note)

- Default settings assuming the use of the Laser Auto Collimator are stored in FILE1 before shipment from the factory. Load FILE1 when you wish to return to default settings.
- Do not overwrite FILE1. Otherwise, all default settings will be lost.
- **At power on, the system will start with the last saved or loaded file.**
- **At power on, the system will start with the last saved or loaded file number and mode of operation.**

7.1.2 Measurement Using Saved Setting Data

This section applies to the measurement conditions that are set already. Follow steps shown below to perform measurement using existing data. At power on, the system will start with the last saved or loaded file. See the applicable sections (numbers written to the left) for details.

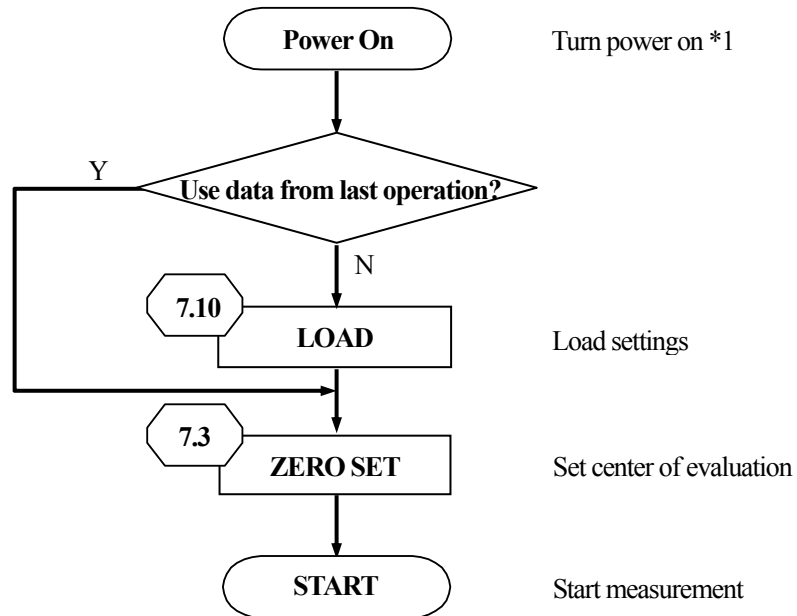

(Note)

- Default settings assuming the use of the Laser Auto Collimator are stored in FILE1 before shipment from the factory. Load FILE1 when you wish to return to default settings.
- Do not overwrite FILE1. Otherwise, all default settings will be lost.

***1 “Load ERROR!!” will appear when the saved data contain an error at power on.**

When this occurs, select OK in the memory initialization confirmation screen and start again. Angle calibration is required after memory initialization. See “10. ANGLE CALIBRATION” for details about angle calibration.

7.2. Setting Screen & Contents

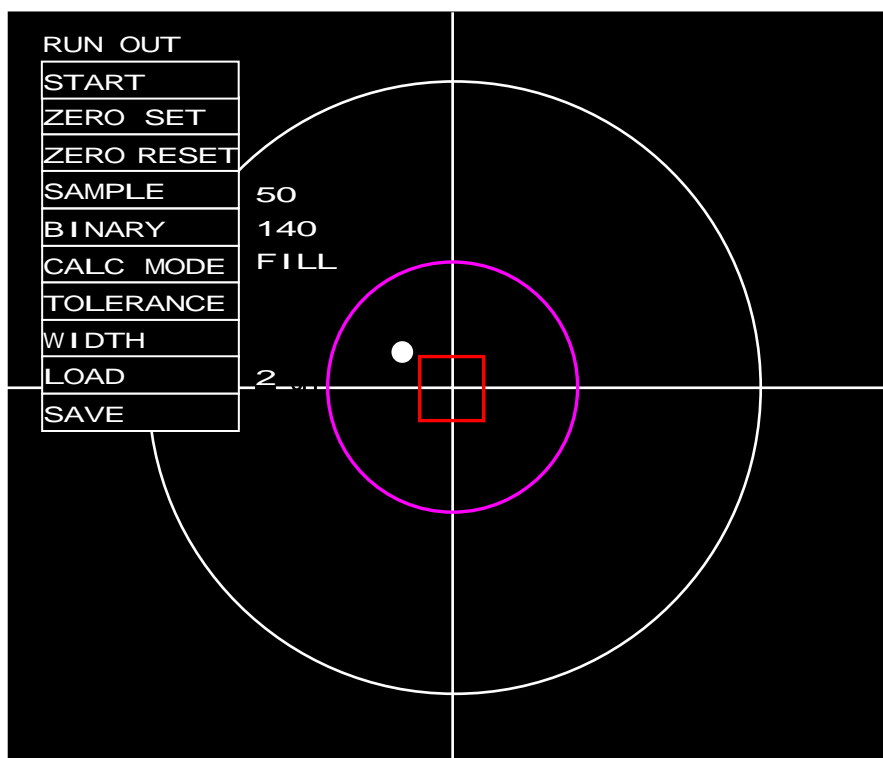

Setting Items

Name	Content Description	Setting Value	Page
START	Start to measure the runout	-	6
ZERO SET	Set the point zero(Angle 0 deg). Measurement value on Measurement screen will be set to zero.	-	7.3
ZERO RESET	Zero point is set to the center of measurement range.	-	7.4
SAMPLE	Set the number of sampling.	1~999	7.5
BINARY	Set the binary threshold at the centroid calculated.	30~254	7.6
CALC MODE	Set the tilt width calculation mode.	FILL / FEAT	7.7
TOLERANCE	Set the judgment area.	D / X-Y / OFF	7.8
WIDTH	Set the tilt width judgment size.	ON / OFF	7.9
LOAD	Reading out setting data	1~5	7.10
SAVE	Save the setting data	1~5	7.11

7.3. ZERO SET

When setting up the measurement system, use the two-axis tilt stage (HB10) to move the light spot from the laser light source mechanically as close to the intersection of the reticle in the screen (preliminary alignment). Then, select "ZERO SET" in the setting screen.

•7.3.1 Setting the zero point

It is must be a reference point of tolerance (indicated by pink lines) at the zero point of measurement value. Can be shifted tolerance and zero point at the range of measurement.

- 1)After angle calibration is completed, select [ZERO SET] and press [ENT] key.
- 2)Using a master substrate, etc, display a detected light that is to be defined as the zero point.
- 3)Press [ENT] key.
- 4)Centroid position of light spot will be the zero point.

[ZERO SET] appears in the upper left corner of the screen.

The angle from the center of measurement range is displayed in the lower left corner of the screen.

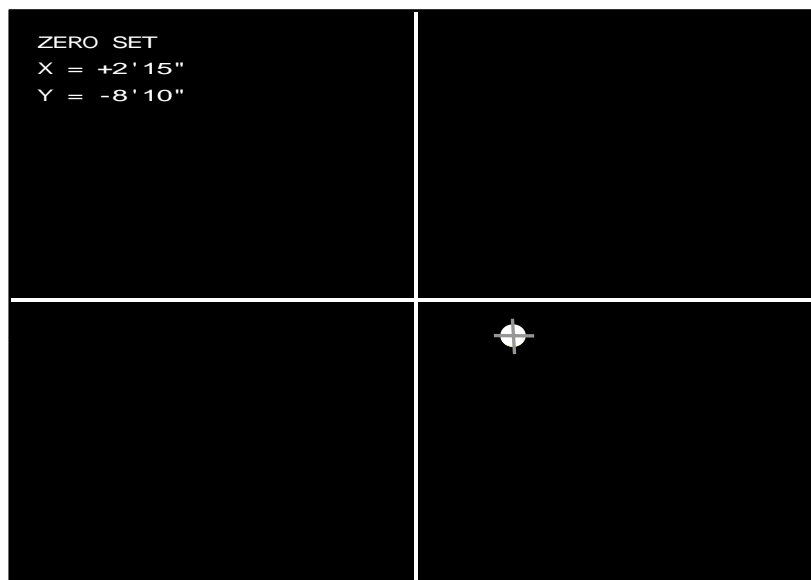

7.4. ZERO RESET

Set the zero point to the center of measurement range.



- 1) OK : The zero point is changed to the center of measurement range.
- 2) CANCEL : The zero point remains unchanged.

7.5. SAMPLE

Set the number of image frames (sampling) to be overlaid for runout measurement.



Spots should connect to each other and their traces, when connected, should form a single closed surface. An error is returned when there are two or more such closed surfaces. When an error occurs, the sampling frequency should be changed.

* A greater sampling will increase the processing time.

• Runout processing

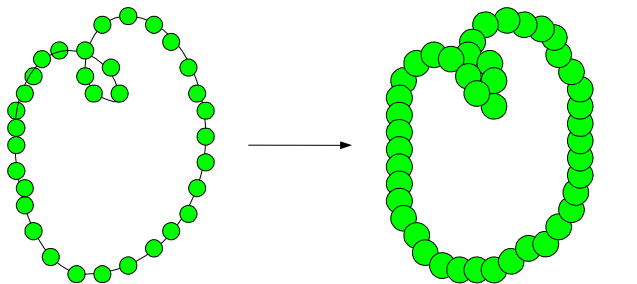

When images are overlaid, spots will form an orbit.

Pixels are enlarged so that the spots are connected to each other.



Pixel shrinks to the extent that the pixel is expanded, and the returning center of area and width are measured.

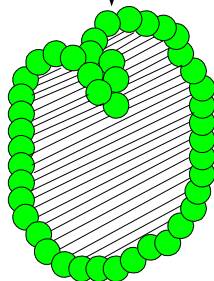

When the spots are connected, fill up within the area.

Caution : The exact center of gravity will not be determined if the spots are not connected. When this occurs, increase the number of samples so that the spots are connected. Measurement will not be performed if they do not form a closed line.

7.6. BINARY

Set the binary threshold at the tilt measurement.

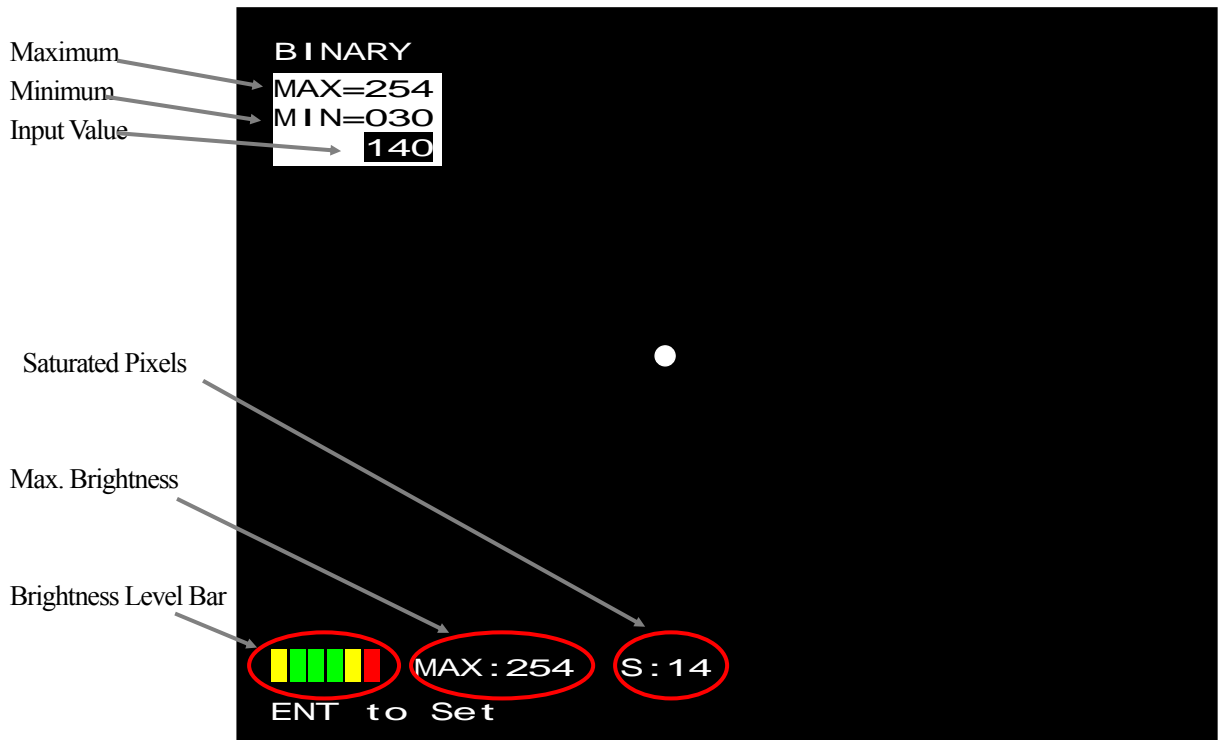

Setting Screen

- 1) Maximum : Input maximum value
- 2) Minimum : Input minimum value
- 3) Input Value :
 - ⬆ Key : Threshold increase
 - ⬇ Key : Threshold decrease
 - ENT Key : OK
 - MENU Key : Cancel
- 4) Saturated Pixels : Luminance is pixels of 254 or more
- 5) Max. Luminance value : Video Max. Luminance
- 6) Luminance Level Bar : See "4.1. Luminance Level Bar"

7.7. CALC MODE

The center of judgment is set to the center of measurement range.

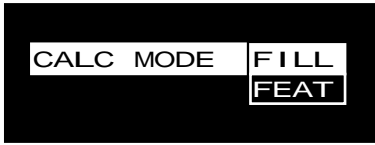

- 1) FILL : Calculate the width from the center of the closed line along X and Y directions.
- 2) FEAT : Determine the tilt of the area inside the closed line and calculate the lengths of the major and minor axes in reference to the tilt.

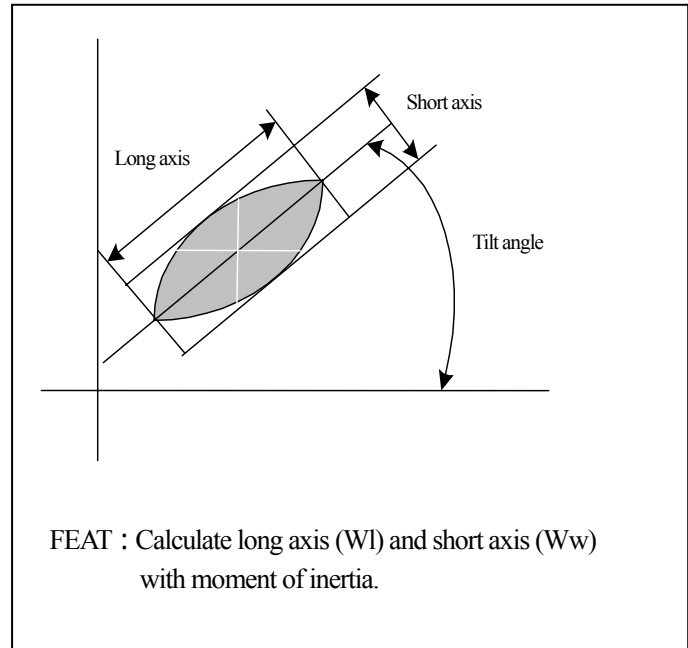
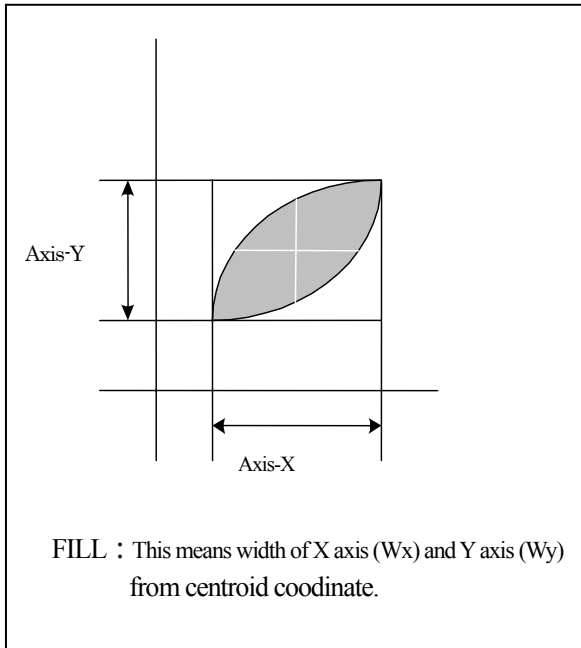

7.8. TOLERANCE

The judgment range of the runout center position is set.

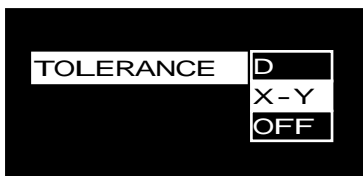

- 1) D : Set the circle for the range of judgment.
Set the radius from the center of tolerance.
- 2) X-Y : Set the square for the range of judgment.
Set X and Y from the center of tolerance.
- 3) OFF : No judge.

7.8.1 In case of setting circle

Enter the absolute value of the judgment angle using [\uparrow][\downarrow][ENT] Keys. The cursor moves to the next higher digit each time [ENT] key is pressed. The change is finalized when the highest digit is set.

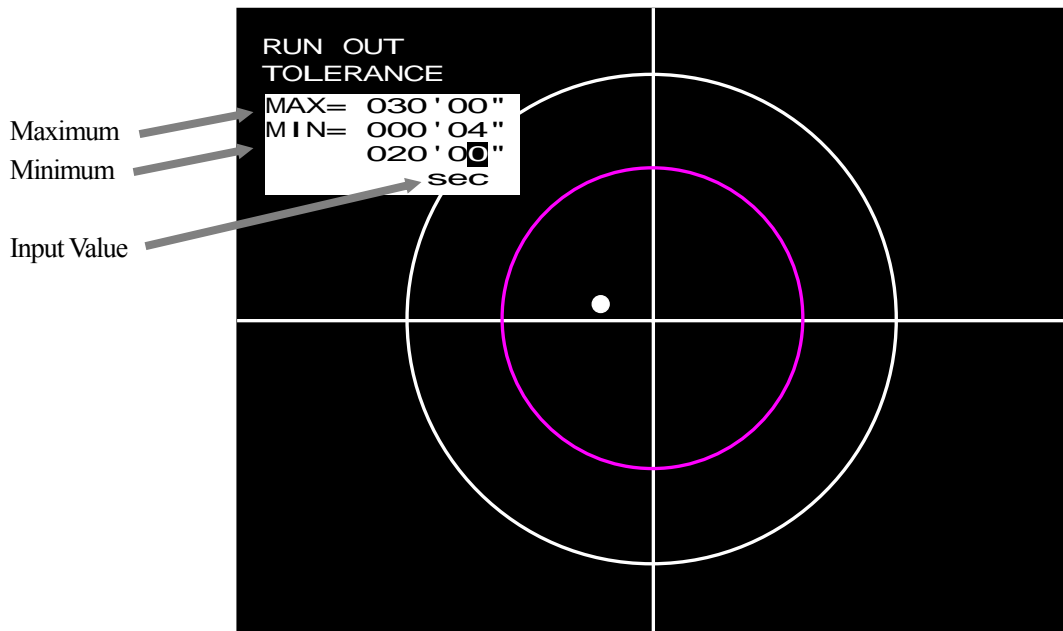

7.8.2 In case of X-Y setting

Select each tolerance of the square and input: XL(Left) , XH(Right) , YH(Upper) , YL(Bottom).

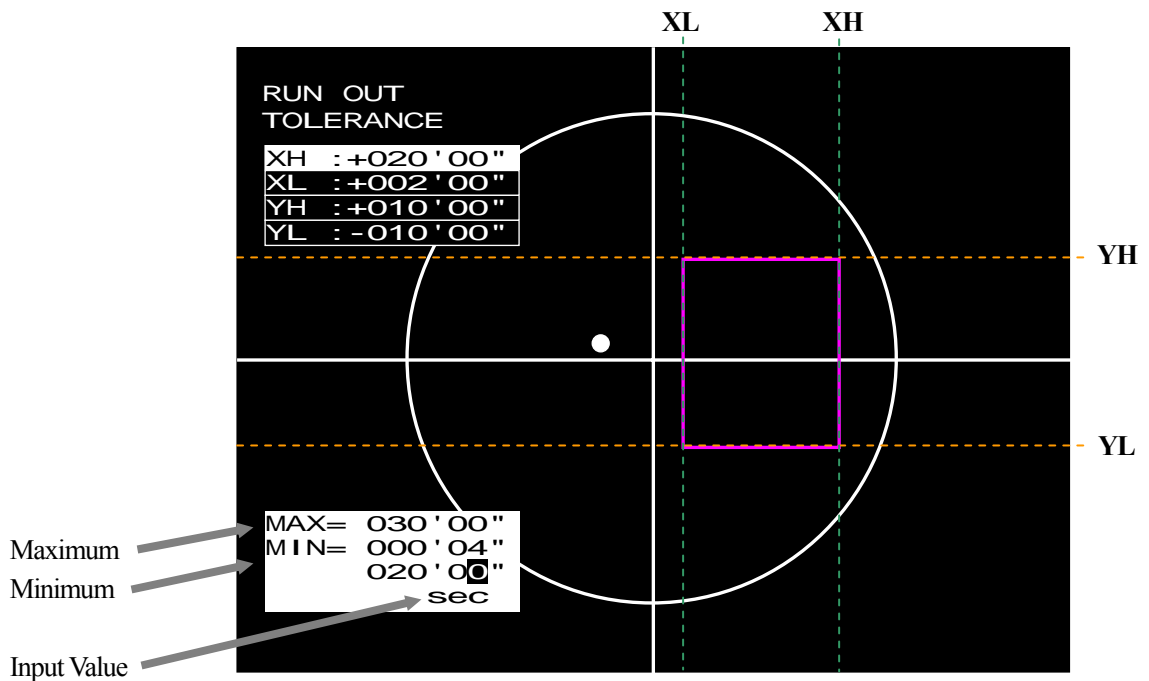

7.9. WIDTH

Set the runout width judgment.



- 1) ON : Set runout width judgment to ON and enter the judgment width.
- 2) OFF : Runout width judgment is not performed.

7.9.1 Judgment width setting

Setting items differ by the method of runout width calculation.

FILL : Wide_X (X-axis angle) , Wide_Y (Y-axis angle)

FEAT : Width (minor axis angle) , Length (major axis anglr)

* See Section 7.7 for more information about FILL and FEAT.

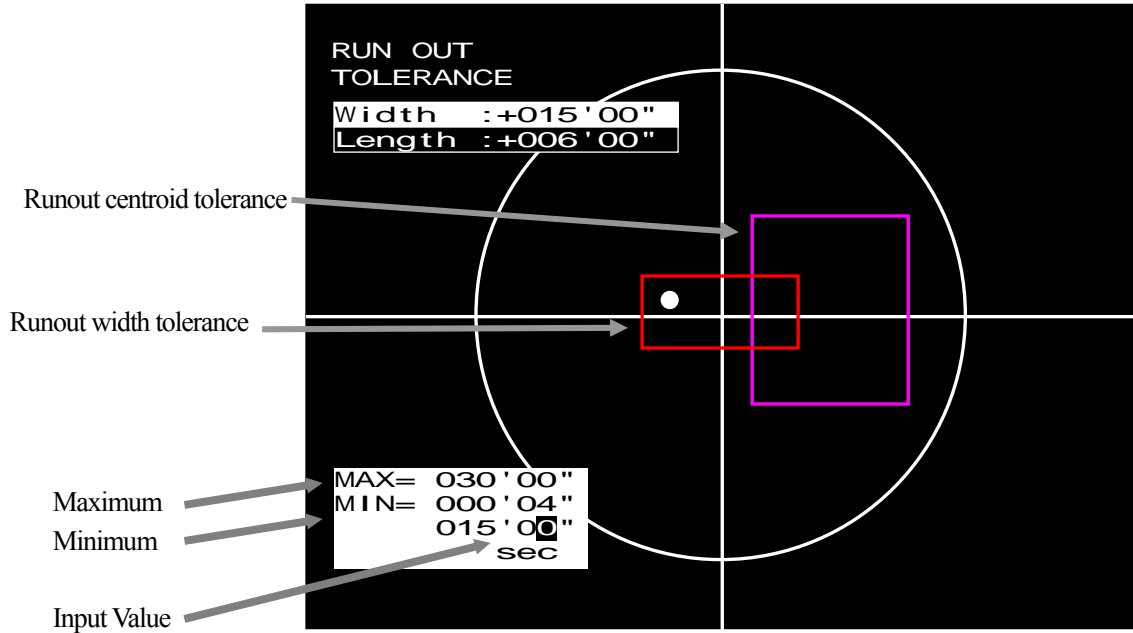

7.10. LOAD

Save and Reading data

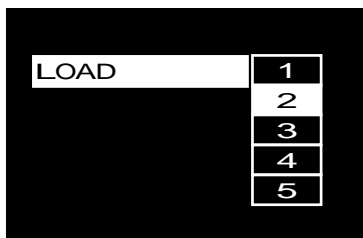

1) 1~5 : Load data from the selected number.

An error is returned when no data have been saved under the selected number.

(Note)

- Default settings assuming the use of the Laser Autocollimator are stored in FILE1 before shipment from the factory.
- Load FILE1 when you wish to return to default settings.

* Each file contains angle calibration data in addition to the conditions of measurement.

Measurement conditions can be saved for up to five auto collimators having different ranges of measurement.

7.11. SAVE

Saving setting data

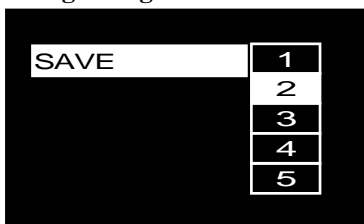

1) 1~5 : Angle measurement conditions and system data are saved under the selected number.

(Note)

- Default settings assuming the use of the Laser Autocollimator are stored in FILE1 before shipment from the factory.

* Each file contains angle calibration data in addition to the conditions of measurement.

Measurement conditions can be saved for up to five auto collimators having different ranges of measurement.

8. 3 BEAM Measurement

8.1. Sub-beam tilt angle measurement basic functions

Sub-beam tilt angle measurement is used to measure the sub-beam (± 1 sub-beam) resulting from grating of an optical pickup.

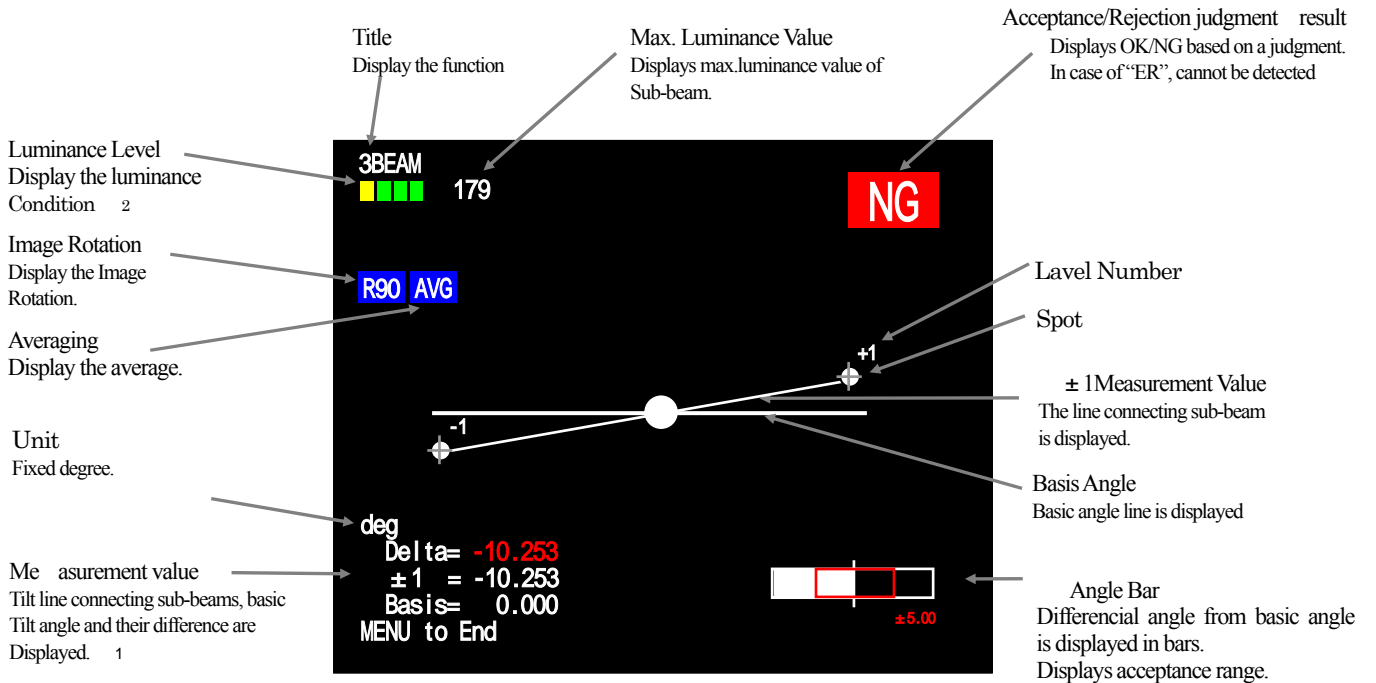

*1 Measurement Value

θ_{Delta} : Difference angle of Basic tilt angle and The tilt angle connects the sub beam.

$\theta_{\pm 1}$: The tilt angle connects the sub beam.

θ_{Basis} : Basic tilt angle

*2 Luminance Level

No.	Bar display	Color	Status	Content
1		Black	Under (Error)	Unmeasurable as the minimum luminance level is not reached: See "9.4. THRESHOLD"
2		Yellow	Low	Measurable but unstable due to low luminance.
3		Green	Good	Adequate luminance for measurement. (three green bars represent the best condition for measurement).
4		Green	Good	
5		Green	Best	
6		Yellow	High	Measurable but luminance is saturating.
7		Red	Over (Error)	Unmeasurable due to saturated pixels (pixels with level 254) 3 pixel or more

8.2. Main beam measurement basic functions

Main beam measurement is used to measure the main beam resulting from grating of an optical pickup.

I/O IN_A set to ON : Main beam measurement is performed.

IN_A set to OFF : Sub-beam tilt angle measurement is performed.

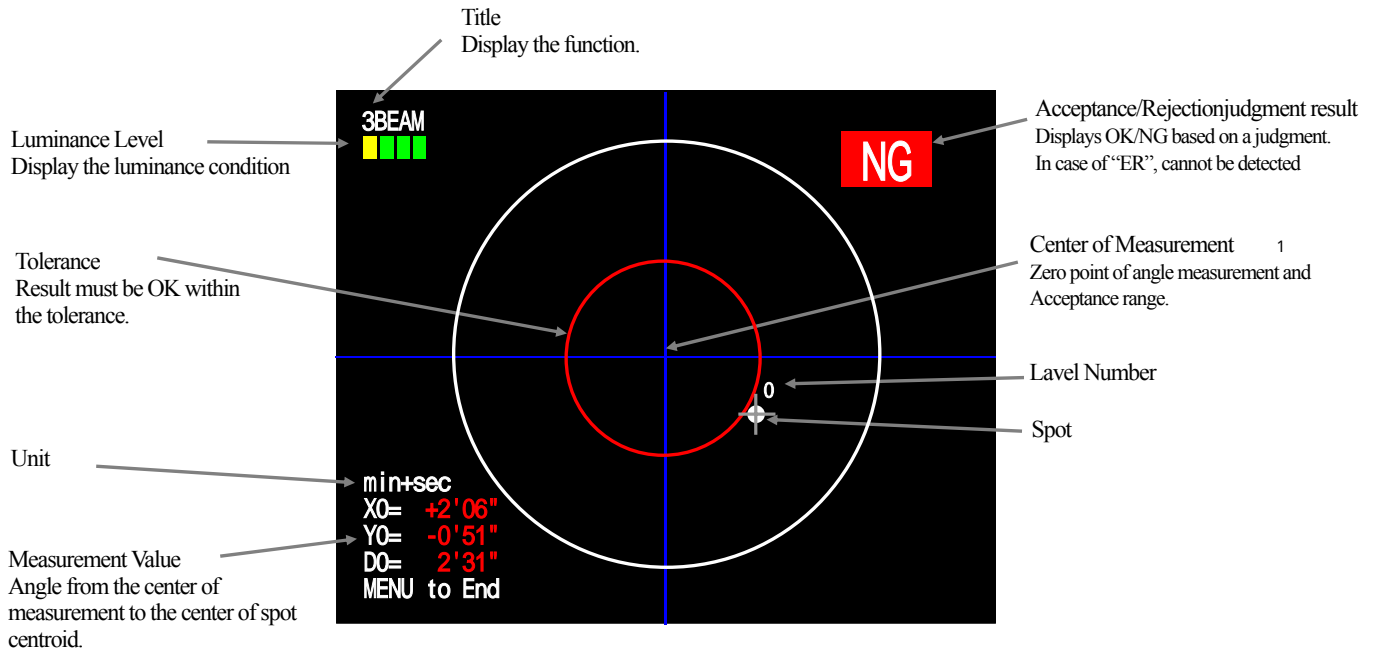

*1 Center of measurement

Center of measurement is zero point randomly set the judgment angle.

See "9.3 ZERO SET" for details.

9. 3BEAM Measurement Setting

9.1. 3BEAM Measurement Usage

9.1.1 New measurement (3BEAM MeasurementSetting)

Angle measurement setting is required before using the processing unit for the first time or whenever resetting of measurement conditions is necessary. Follow setting steps shown below and see the applicable sections (numbers written to the left) for details.

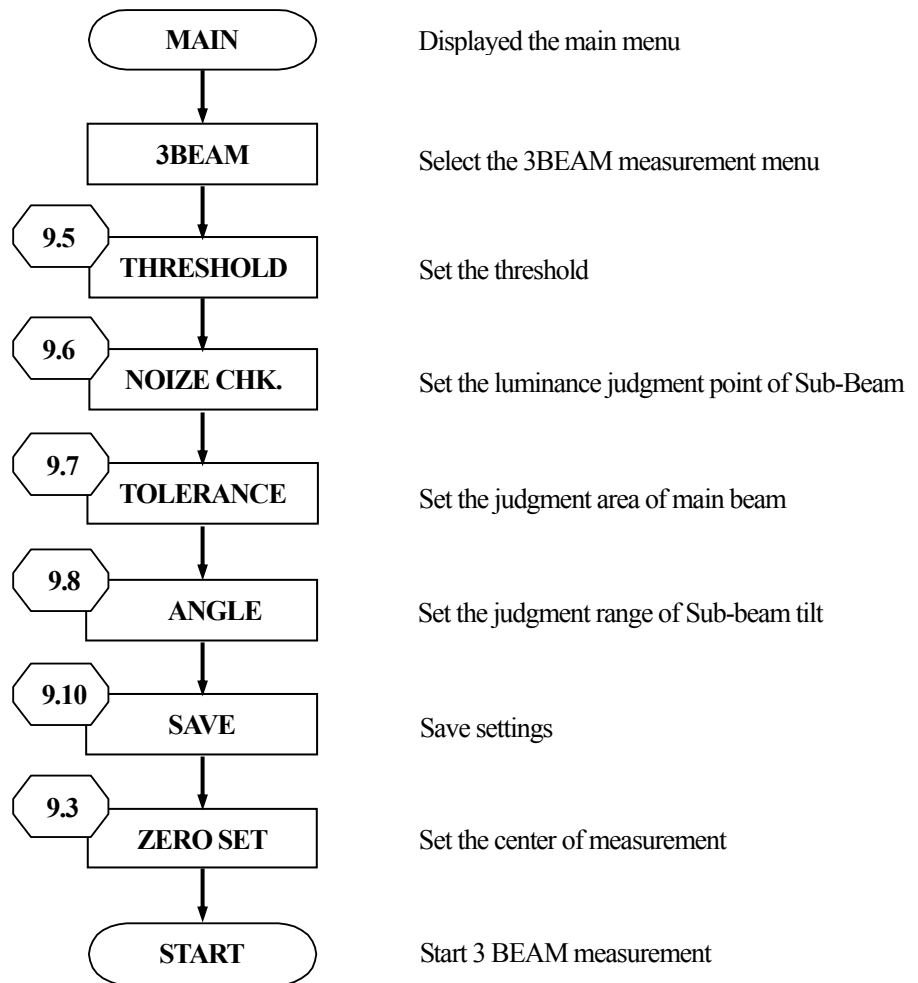

(Note)

- Default settings assuming the use of the Laser Auto Collimator are stored in FILE1 before shipment from the factory. Load FILE1 when you wish to return to default settings.
- Do not overwrite FILE1. Otherwise, all default settings will be lost.
- Whenever settings are altered, save the new data for future use.
 - At power on, the system will start with the last saved or loaded file number and mode of operation.

9.1.2 Measurement using the saved setting data

This section applies to the measurement conditions that are set already.

Follow steps shown below to perform measurement using existing data.

At power on, the system will start with the last saved or loaded file number and mode of operation.

See the applicable sections (numbers written to the left) for details.

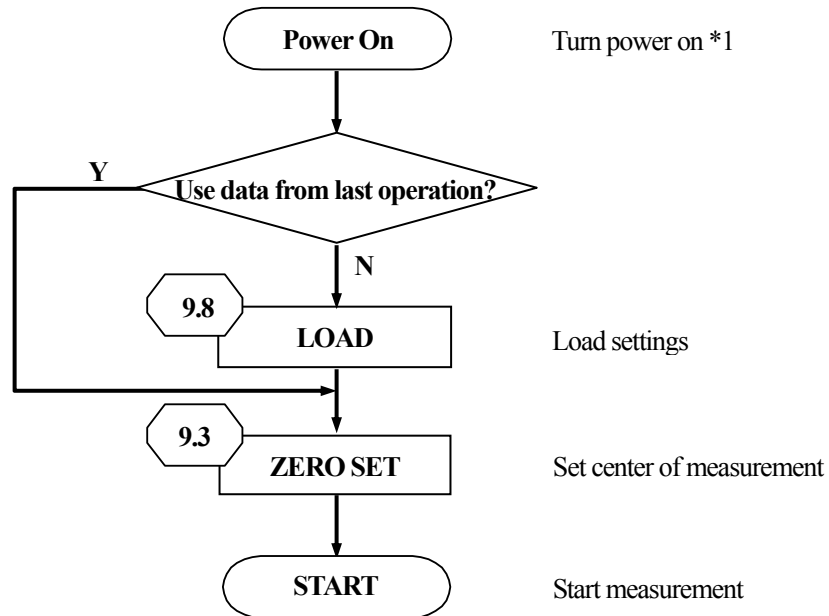

(Note)

- Default settings assuming the use of the Laser Auto Collimator are stored in FILE1 before shipment from the factory. Load FILE1 when you wish to return to default settings.
- Do not overwrite FILE1. Otherwise, all default settings will be lost.

***1 “Load ERROR!!” will appear when the saved data contain an error at power on.**

When this occurs, select OK in the memory initialization confirmation screen and start again.

Angle calibration is required after memory initialization. See “10. ANGLE CALIBRATION” for details about angle calibration.

9.2. Setting Screen & Contents

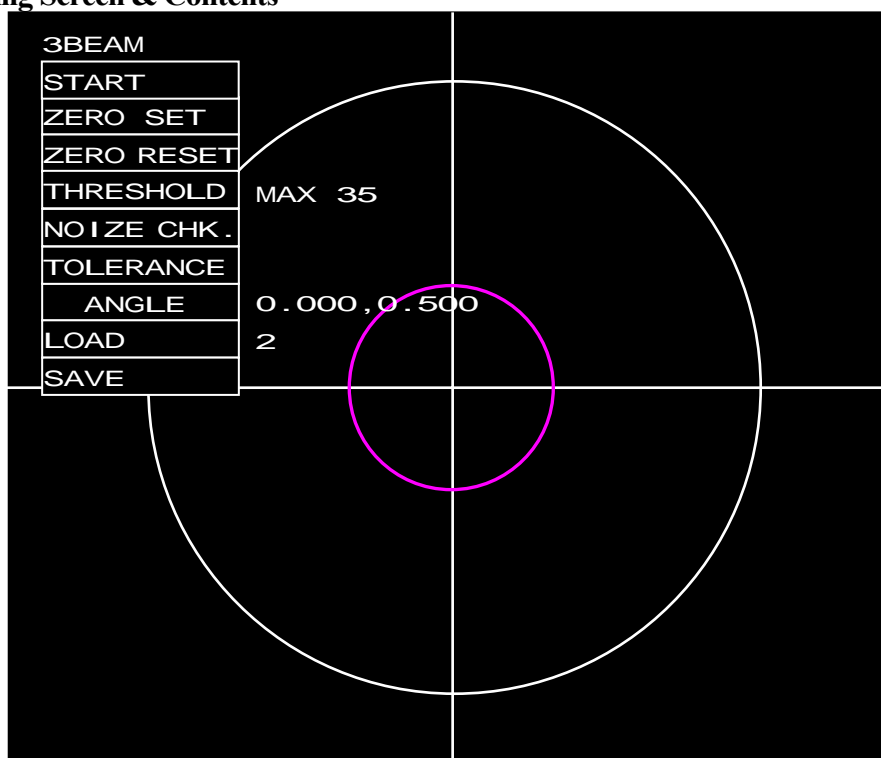

Setting Screen

Setting Items

Name	Content Description	Setting Value	Page
START	Start the 3 BEAM measurement.	-	8
ZERO SET	Set the center of judgment.	-	9.3
ZERO RESET	Center of judgment is set to the center of measurement range.	-	9.4
THRESHOLD	Set the luminance threshold.	30~254 / 1~99	9.5
NOIZE CHK.	Judge the sub-beam luminance threshold.	-	9.6
TOLERANCE	Set the tolerance of main detected light.	CIRCLE / X-Y / OFF	9.7
θANGLE	The judgment tilt angle of the sub beam is set.	BASIS AVERAGE JUDGE RANGE JUDGE OFF BAR RANGE BAR OFF	9.8
LOAD	Reading out setting data	1~5	9.9
SAVE	Save the data	1~5	9.10

9.3. ZERO SET

When setting up the measurement system, use the two-axis tilt stage (HB10) to move the light spot from the laser light source mechanically as close to the intersection of the reticle in the screen (preliminary alignment). Then, select “ZERO SET” in the setting screen.

9.3.1 Setting the zero point

This means zero point of measurement value, and basic point of tolerance (indicated by magenta lines)
The center of measurement and the tolerance can be shifted as needed within the range of measurement.

- 1) After angle calibration is completed, select [ZERO SET] and press [ENT] key.
- 2) Using a master substrate, etc, display a detected light.
- 3) Press [ENT] key.
- 4) The centroid of spot is a zero point.

[ZERO SET] appears in the upper left corner of the screen.

The angle from the center of measurement range is displayed in the lower left corner of the screen.

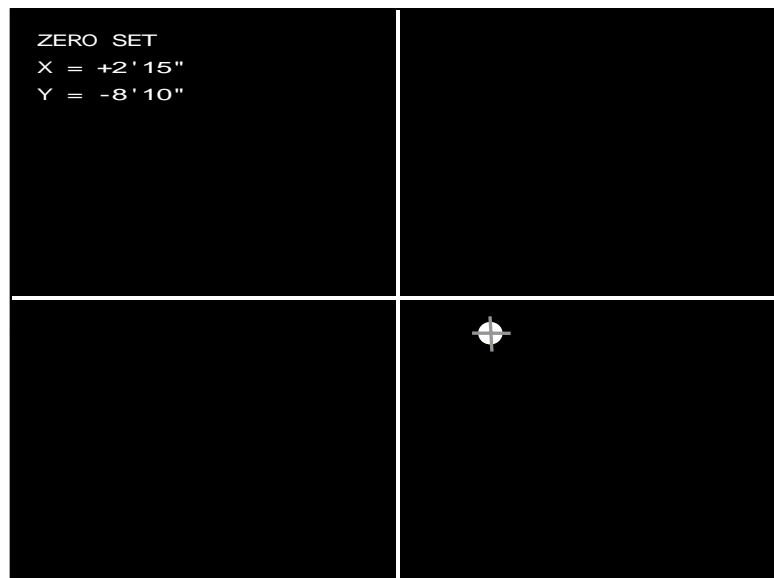

See Section 5.3 for definitions of centers (optical center, center of measurement range and the center of tolerance).

9.4. ZERO RESET

Set the center of measurement in the center of measurement range.



- 1) OK : The center of measurement is changed to the center of measurement range.
- 2) CANCEL : The center of measurement remains unchanged.

9.5. THRESHOLD

Set the luminance threshold.



- 1) LEVEL : Set the threshold between 30~254.
- 2) MAX % : Set luminance 1~99% of the maximum luminance as the threshold.

• Example of MAX % setting

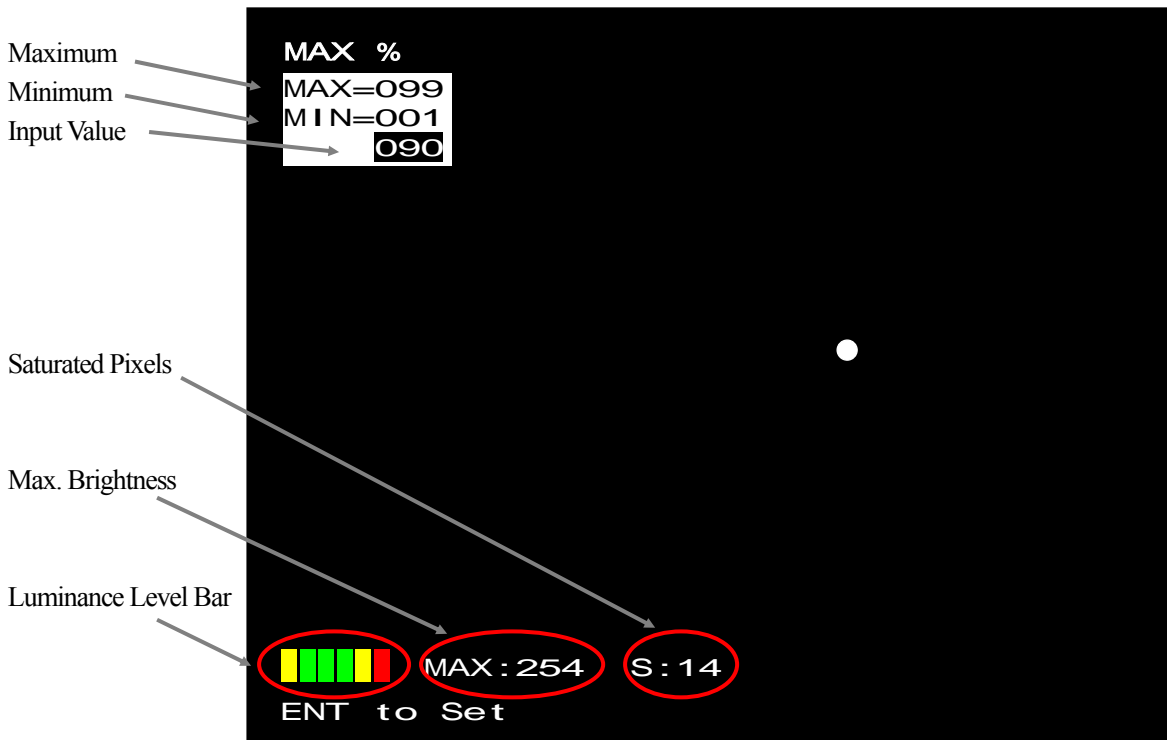

Setting Screen

9.6. NOIZE CHK.

Set the luminance judgment of the sub-beam.



- 1) ON : Sub-beam luminance judgment is performed and set.
 HIGH : Set the upper limit of luminance (NG if exceeded).
 LOW : Set the lower limit of luminance (NG if not reached).
- 2) OFF : No Sub-beam luminance judgment.

- Setting screen for luminance judgment

“H” represents the upper limit; “L” represents the lower limit.

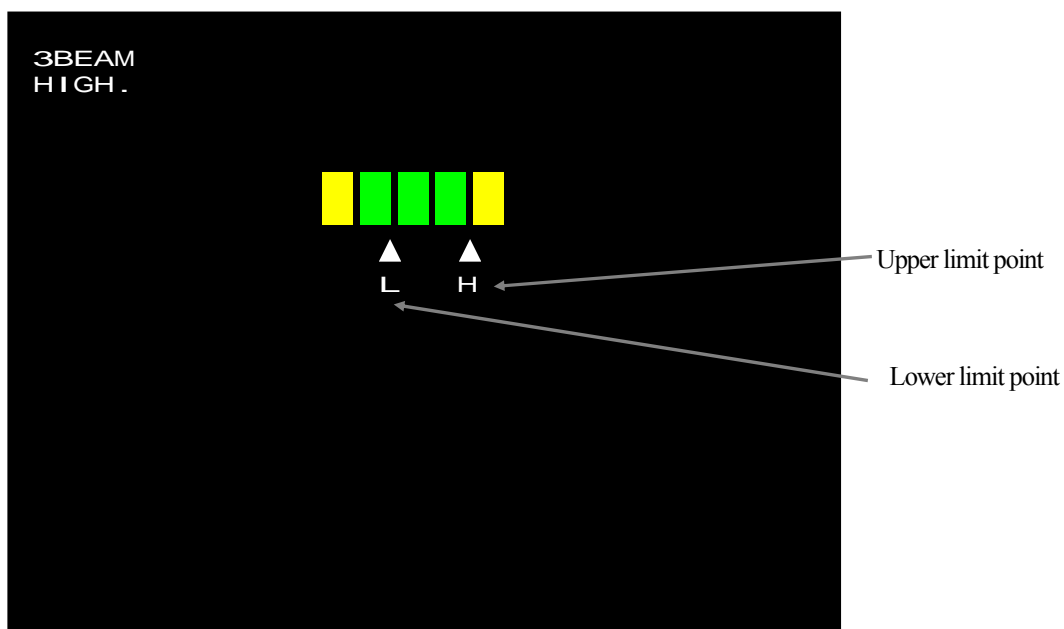

Select HIGH or LOW and move the point using “↑” and “↓” key.

OK is returned when the measured luminance falls between H and L.

NG is returned in other conditions.

9.7. TOLERANCE

Set the judgment range of the main beam.



- 1) CIRCLE : Set the circle (oval) tolerance.
Set the angle X and Y that is center of measurement-centered.
- 2) X-Y : Set the square tolerance.
Set the angle X and Y that is center of measurement-centered.
- 3) OFF : No judgment processing

• Setting the tolerance

The CIRCLE setting screen and the X-Y setting screen are identical.

Set X (horizontal width) and Y (vertical width).

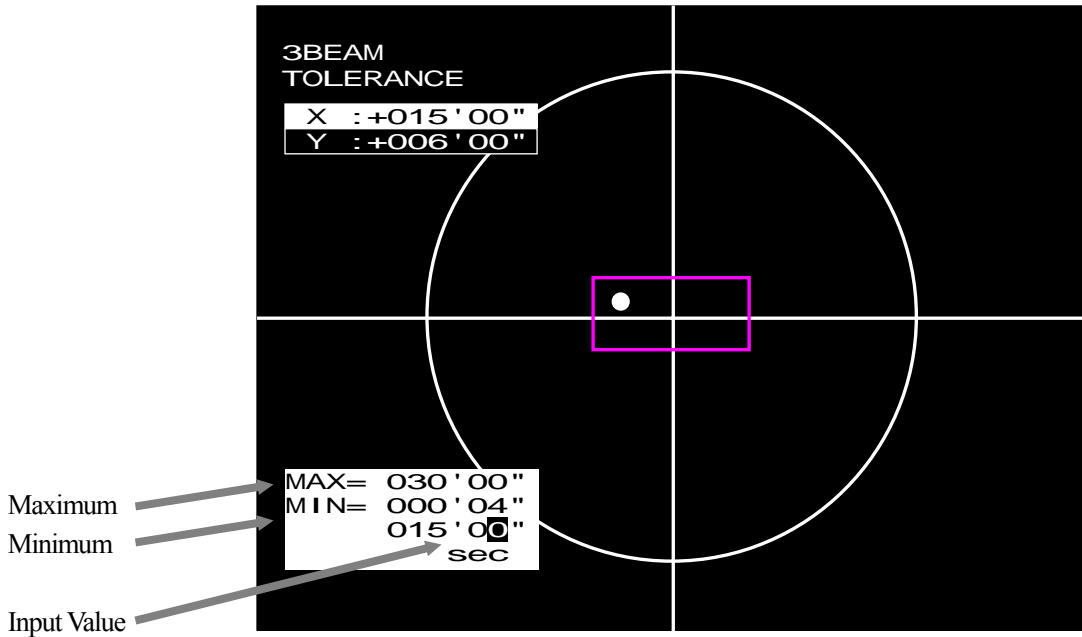

9.8. θ ANGLE

Setting of the judgment range for the tilt angle for sub-beam light.

ANGLE	BASIS
	AVERAGE
	JUDGE RANGE
	JUDGE OFF
	BAR RANGE
	BAR OFF

- 1) BASIS : Set the basic tilt angle.
Set the tilt angle between $\pm 90.000^\circ$.
3 BEAM MEAS.: Measure the angle that is connected between the sub-beam (2nd. and 3rd. spot) when spots are over 3. And set the basic tilt angle with [ENT] key.
2 BEAM MEAS.: Measure the angle that is connected each 2 spots and set the basic tilt angle with [ENT] key.
VALUE : Enter the basic tilt angle.
- 2) AVERAGE : Set the averaging method.
4 : Calculate the tilt angle from 4 continuous moving averages.
6 : Calculate the tilt angle from 6 continuous moving averages.
8 : Calculate the tilt angle from 8 continuous moving averages.
OFF : Averaging is not performed.
- 3) JUDGE RANGE : Set the tilt range.
The tilt must be set between $0.001 \sim 90.000^\circ$.
- 4) JUDGE OFF : No tilt judgment.
- 5) BAR RANGE : Set the bar display range.
Bar display range must be set between $0.10 \sim 100.00^\circ$.
- 6) BAR OFF : No Bar display.

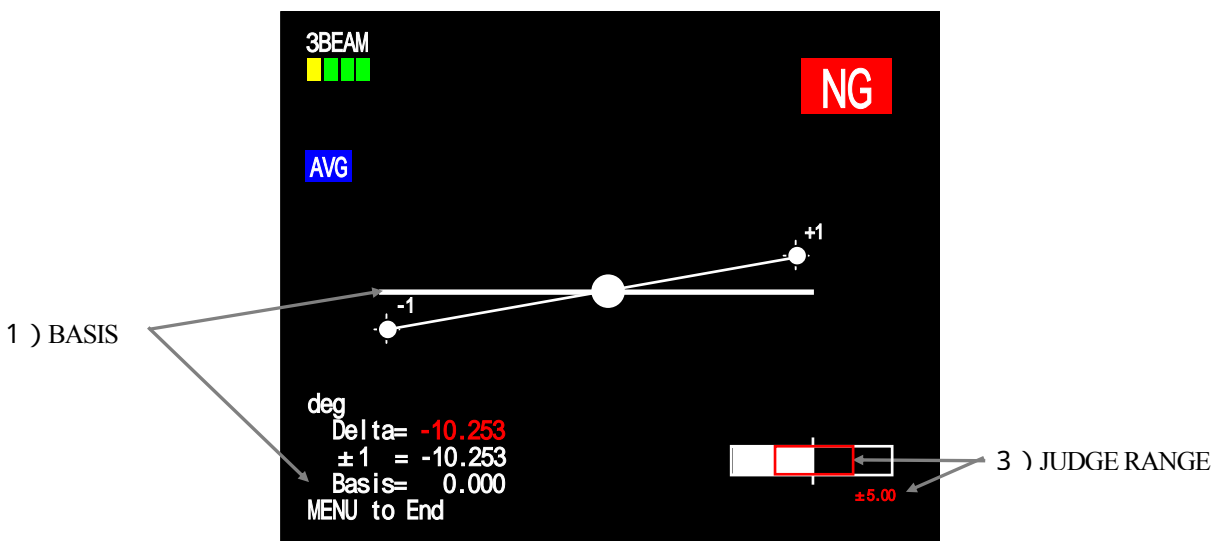

9.9. LOAD

Reading out setting data

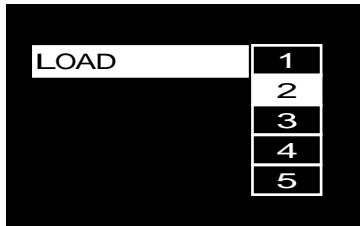

- 1) 1~5 : Load data from the selected number.
An error is returned when no data have been saved under the selected number.

(Note)

- **Default settings assuming the use of the Laser Auto Collimator are stored in FILE1 before shipment from the factory.**
- **Load FILE1 when you wish to return to default settings.**

* Each file contains angle calibration data in addition to the conditions of measurement.
Measurement conditions can be saved for up to five auto collimators having different ranges of measurement.

9.10. SAVE

Saving setting data

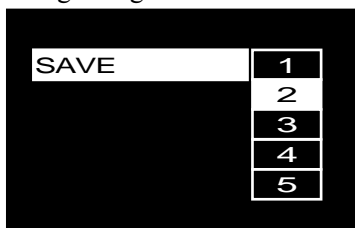

- 1) 1~5 : Angle measurement conditions and system data are saved under the selected number.

(Note)

- **Default settings assuming the use of the Laser Auto Collimator are stored in FILE1 before shipment from the factory.**

* Each file contains angle calibration data in addition to the conditions of measurement.
Measurement conditions can be saved for up to five auto collimators having different ranges of measurement.

10. Angle Calibration

10.1. About Angle Calibration

Angle calibration is a series of steps followed to determine the angle displacement per pixel of the Laser Auto Collimator's CCD camera (pixel resolution).

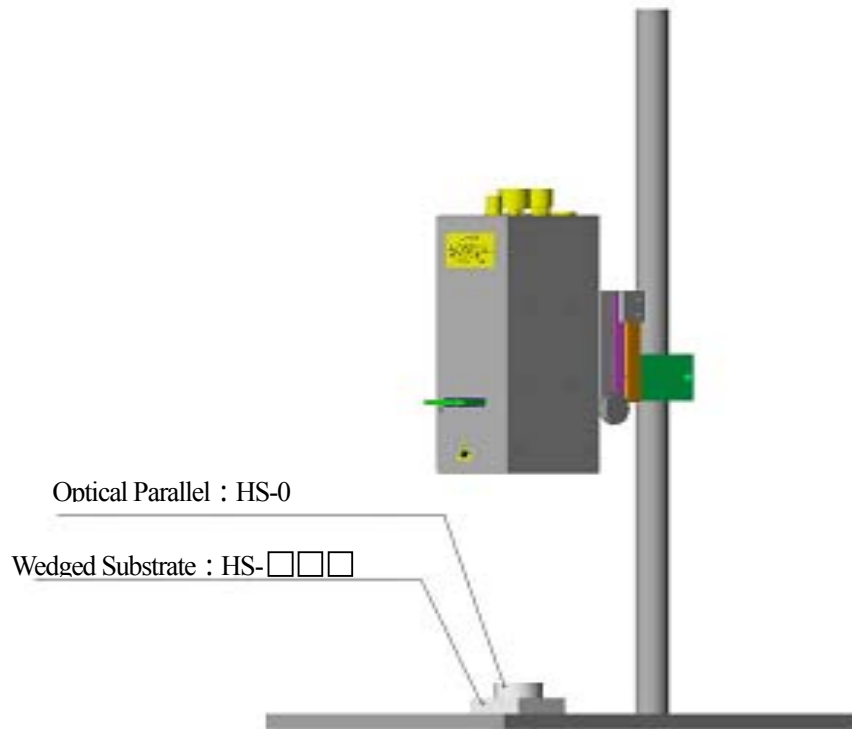

Angle calibration requires a parallel mirror (HS-0) to define the parallelism and a wedged substrate (HS-□□□ or other standard substrates) to define the angle standard.

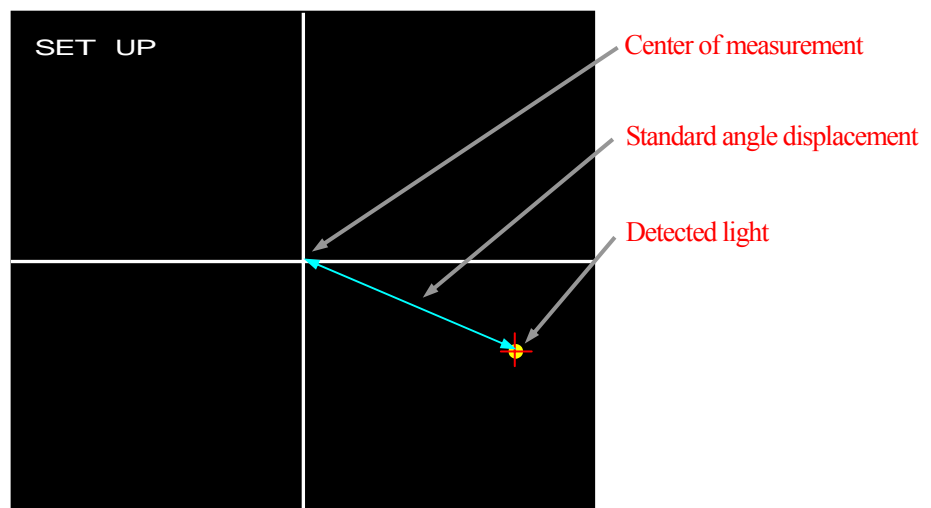

SET UP Screen

$$\frac{\text{Angle of wedged substrate (deg)}}{\text{Detected light from SET-UP - Center of measurement range(pixel)}} = \text{Angle per pixel (deg / pixel)}$$

10.2 Flow of Angle Calibration

This chart shows the flow of operation for using a new laser autocollimator or performing angle calibration. Angle calibration requires a parallel mirror (HS-0) to define the parallelism and a wedged substrate to define the angle standard (HS-□□□ or other standard substrates that meet the Laser Auto Collimator range).

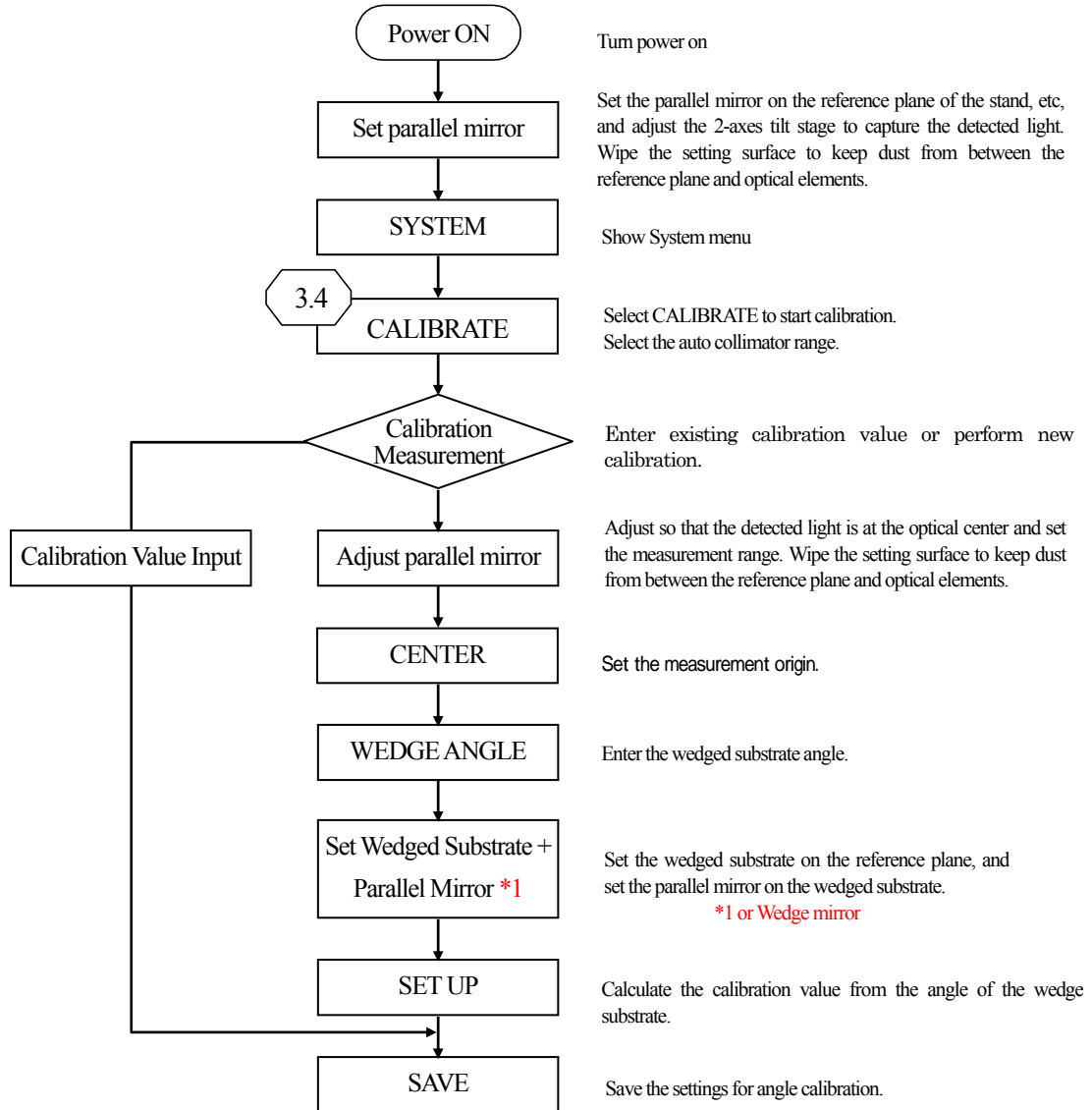

(Note)

- Set the distance from the laser output of the Laser Auto Collimator to the parallel mirror to the object measurement distance written in the catalog.
- When using a wedged substrate, place the parallel mirror on the wedged substrate and verify that only one light dot is in view before making any adjustments. If you are using a wedged mirror, proceed without parallel mirror.
- Default settings assuming the use of the Laser Auto Collimator are stored in FILE1 before shipment from the factory. Load them as needed.
- Do not overwrite FILE1. Otherwise, all default settings will be lost.

10.3. Calibration Menu (SYSTEM-CALIBRATE)

10.3.1 CALIBRATE

The measurement range of the Laser Auto Collimator is set as shown below (not a software technique to change the scaling factor).

- The measurement range is set to the Laser Auto Collimator head before shipment from the factory.
- A new measurement range must be set when using a new Laser Auto Collimator or when performing a new angle calibration.
- Select and proceed to angle calibration immediately.
- Save calibration to complete the angle calibration.
- This setting can only be achieved while in reflection measurement mode (not in external incidence measurement mode). See “1.2.2 External Incidence Measurement” about the method of switching modes.

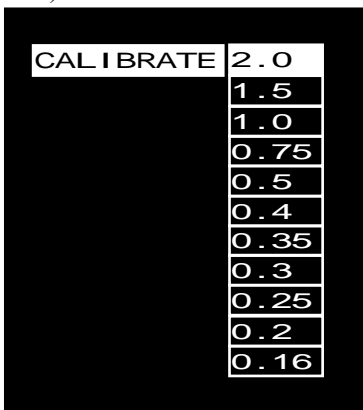

- 1) Select "CALIBRATE " on the Setting screen, and press [ENT] Key.
- 2) Select a Suruga Seiki’s Auto Collimator from the list (measurement range).
- 3) Press [ENT] key to select the calibration method (Section 10.3.2 Calibration Method Selection).

10.3.2 Calibration Method Selection

Select MEASURE (perform calibration) or VALUE (enter calibration value directly).

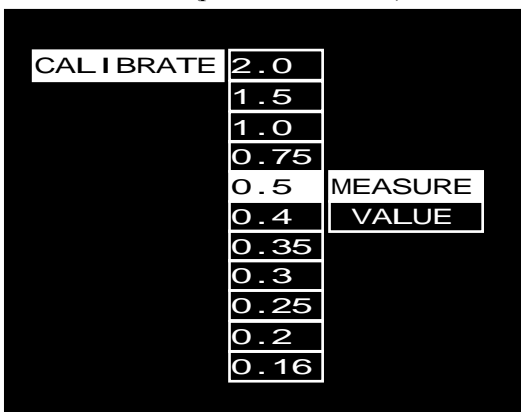

- 1) MEASURE : Perform calibration using wedges (Section 10.3.3 CENTER).
- 2) VALUE : Enter calibration values directly (Section 10.3.6 Calibration Value Input).

10.3.3 CENTER

The center of measurement range is the center for angle calibration.

[CENTER] appears in the upper left corner of the screen when setting the center of measurement range.

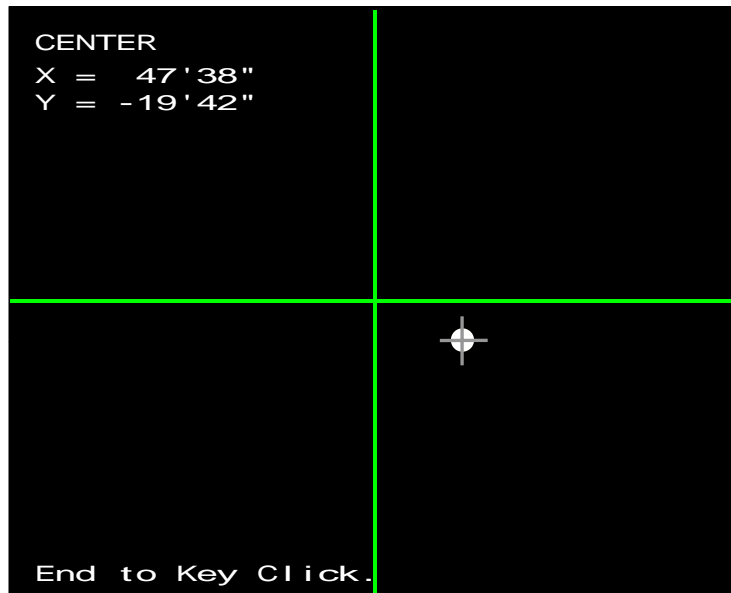

ENT Key : OK
MENU Key : Cancel

- 1) Normally set to the intersection of the green lines that coincides with the optical center
- 2) Press [ENT] key after the center of the spot lands on the intersection of the green lines.
- 3) Proceed to entering the wedged substrate or wedged mirror angles (Section 10.3.4 Input an Angle of Wedged Substrate).

• Definition of centers

A. Optical center

The optical center is the unique center of an optical system of the Laser Auto Collimator. It is adjusted to the center of the CCD built into the Laser Auto Collimator head.

The optical center is the intersection of the default green lines in Section 10.3.2 CENTER.

B. Zero point

The center of measurement range is the zero-point referenced in angle calibration.

The range is set per Section 10.3.2 after selecting Auto Collimator per Section 10.3.1. Normally, the center of measurement range should be aligned with the optical center (A) above.

C. Center of acceptance range

The center of acceptance range is the zero-point of measurement value.

Display with blue cross point.

B. Must be same spot center of measurement range and zero point at the setting center of measurement range.

B. Can be shifted zero point with ZERO SET after setting center of measurement range.

D. Center of tolerance

Can be offset the center of tolerance (center of pin circle) from zero point at the only OFFSETTILT mode.

10.3.4 Input An Angle Of Wedged

Enter the wedged substrate or wedged mirror angle for angle calibration.

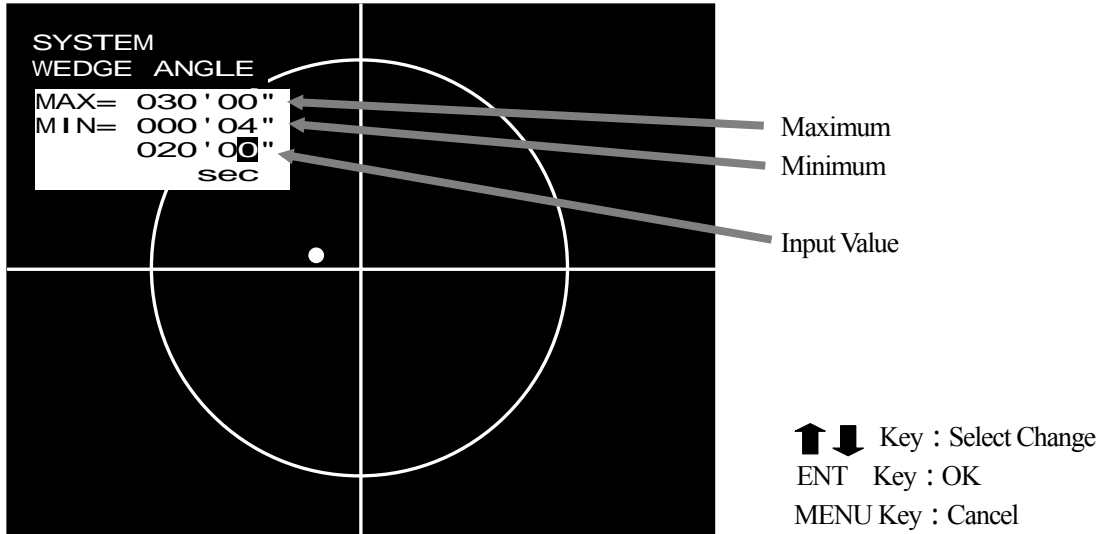

After entering the wedge angle, proceed to Section 10.3.5 for SET UP processing (to actually measure the wedged substrate or wedged mirror).

10.3.5 SET UP

Measure the wedged substrate + parallel mirror or wedged mirror.

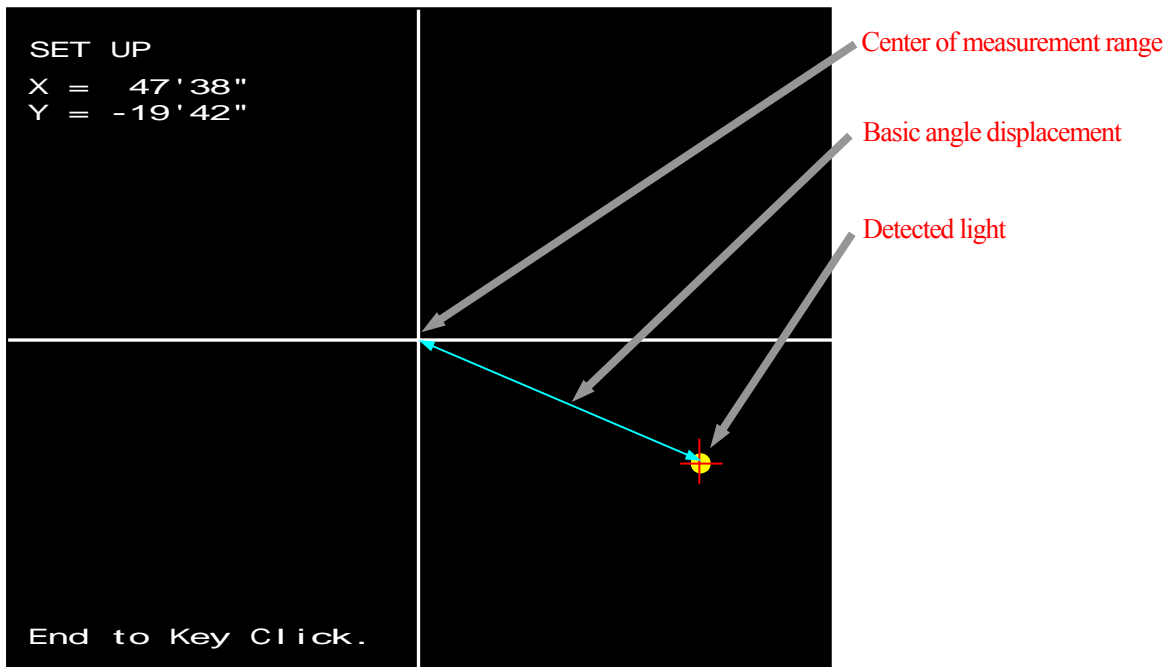

*** SET UP is processed on center of area**

- 1) Confirm the spot from the wedged substrate + parallel mirror or wedged mirror (the wedged mirror is used without the mirror).
- 2) Press [ENT] key to set the calibration angle.
- 3) Proceed to Section 10.3.7 to save the calibration data.

10.3.6 Calibration Value Input

Enter the calibration value directly without performing calibration.

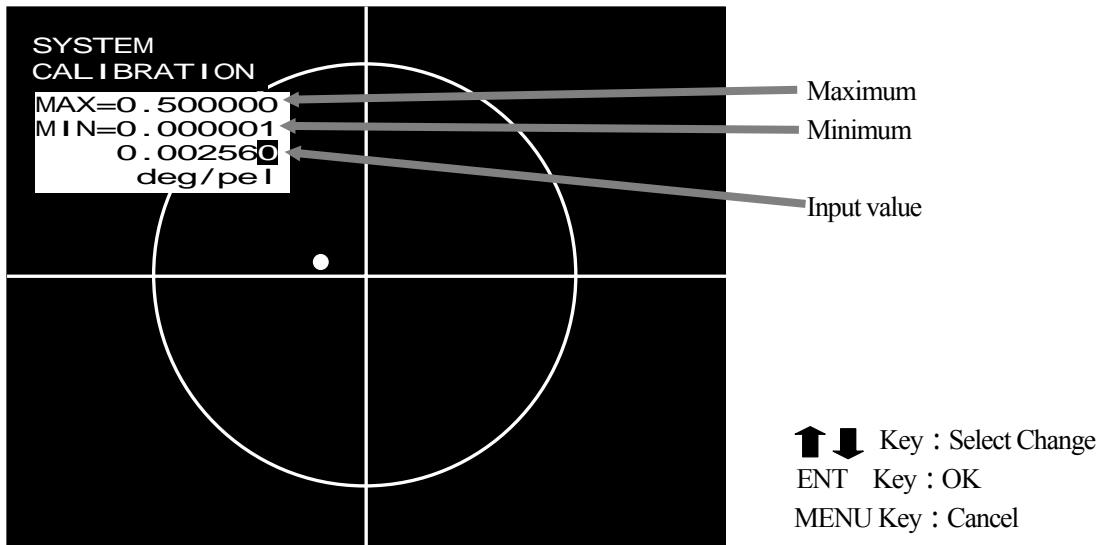

- 1) Enter the calibration value (enter carefully as this affects the result of measurement).
- 2) Proceed to Section 10.3.7 to save the calibration data.

10.3.7 SAVE

This refers to saving the calibration data.

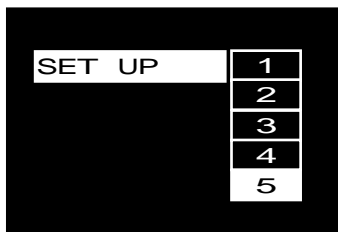

- 1) Select a file number using [↑][↓] Keys.
- 2) Press [ENT] Key to save settings in the selected file.

(Note)

- Optimum (default) settings assuming the use of the Laser Auto Collimator are stored in FILE1 before shipment from the factory.
- Do not overwrite FILE1. Otherwise, all default settings will be lost.

* Each file contains angle calibration data in addition to the conditions of measurement.
Measurement conditions can be saved for up to five auto collimators having different ranges of measurement.

11. Error Message

The error message is displayed under the left of the screen at the error.

Error Message List

Message	Content
Binarized object is nothing .	No optical spot is found.
Binarized objects are more than 2.	There are two or more spots.
Binarized objects are more than 4.	There are four or more spots.
Labels is insufficient.	The specified number of labels is not reached.
Brightness is saturated.	Brightness is saturated.
Max Brightness is Over.	The maximum brightness is exceeded.
Sub binarized object is nothing.	No \pm sub-beam is found.
Sub binarized object is only one.	Only a single \pm sub-beam is found.
Sub binarized objects are over.	There are three or more \pm sub-beams.
Sub beam brightness is saturated.	Brightness of \pm sub-beam is saturated.
Barycenter calculation failure.	The barycenter cannot be established.
Barycenter are more than 2.	There are two or more barycenters.
Area is larger than screen size.	The judgment range is larger than the screen size.
Setting ERROR!!	Angle calibration failed.
Measurement is interrupted.	Interrupted by key or I/O input.
FILE Nothing !!	No file has been saved.
Numeric input error!!	Abnormal value input.
Load ERROR!!	System data loading failed.
Load2 ERROR!!	Measurement data loading failed.
Save ERROR!!	Data save failed.

12. External Control

12.1. Serial Interface

12.1.1 Communication modes

A. External Input Transmission Mode

The result of judgment is sent with the measured value at a rising edge of the HOLD input signal from the external I/O interface (See "12.4. I/O").

(Method of switching to External Input Transmission Mode)

Set [DATA OUT] in Section 3.9 to [I/O].

B. Continuous Transmission Mode

This mode sends the results and measured values about 200ms.

(Method of switching to Continuous Transmission Mode)

The unit is set to External Input Transmission Mode (default) before shipping from the factory.

Set [DATA OUT] in Section 3.9 to [STREAM].

C. Remote Control Mode

A communication command sent from the host equipment enables reading the results and measured values, writing settings, zero setting, etc.

(Method of switching to Remote Control Mode)

Set [REMOTE] in Section 3.11.

See Section 12.2 for command details.

12.1.2 RS-232C Connector (Pin assignment)

The RS232C connector of HIP-1200 has the following pin-outs.

The RS232C cable for connecting to external equipment is a D-sub 9-pin cross cable.

Pins 7-8 are jumped internally.

HIP-1200 side (DE-9P-N(JAE))

Pin No	Signal	Comment
1		
2	RxD	Receive Data
3	TxD	Send Data
4		
5	GND	
6		
7	RTS	Request To Send
8	CTS	Clear To Send
9		

12.1.3 Communication Requirements

- Baud Rate : 9600, 19200, 38400, 57600 bps
- Data Bit : 8bit
- Parity : None
- Stop Bit : 1
- Flow Control : None

12.2. Communication Commands

• Communication Commands List

No	ID Code	Function	Post-processing
1	W000	Zero reset	Send ACK after zero reset
2	W001	Zero set	Send ACK after zero set
3	W003	Switch measurement functions	Send ACK after mode change
4	W010	End measurement	Send ACK after the end of runout measurement
5	W011	Start measurement	Send ACK after the start of runout measurement
6	W020	Remote OFF	Send ACK after remote OFF
7	R022	Read calibration value	Send calibration value
8	W022	Change calibration value	Send ACK after changing calibration value
9	W030	Save file	Send ACK is save successful
10	W031	Switch load files	Send ACK after load and functional change is successful
11	R032	Load system data	Send system data
12	W032	Set system data	Send ACK after system data change
13	R*00	Read measured values	Send measured values
14	R*01	Load a set value	Send specified data
15	R*02	Load all set values	Send all settings
16	W*01	Change a set value	Send ACK after changing the specified item
17	W*02	Change all set values	Send ACK after change
18	W111	Change OFFSETTILT judgment1	Send ACK after change
19	W112	Change OFFSETTILT judgment2	Send ACK after change
20	W310	Switch 3 BEAM main beam measurement	Send ACK after change
21	W311	Switch 3 BEAM sub-beam measurement	Send ACK after change
22	W321	Perform 3 BEAM averaging	Send ACK after change
23	W322	Cancel 3 BEAM averaging	Send ACK after change

* : 1 : Angle Measurement , 2 : Runout Measurement , 3 : 3BEAM Measurement

* The command structure of HIP-500 is supported.

No	ID Code	Function	Post-processing
1	RA	Read measured values	Send measured values
2	RC	Read current settings	Send current settings
3	WA	Zero set	Send ACK after zero set
4	WB	Set tolerance circle range	Send ACK after setting tolerance circle
5	WC	Set tolerance square range	Send ACK after setting new tolerance square
6	WD	Set binary threshold	Send ACK after setting binary threshold
7	WE	Save file	Send ACK is save successful
8	WF	Zero reset	Send ACK after zero reset
9	WG	Set noise level	Send ACK after setting new noise level

12.3 Communication format

12.3.1 External Input Transmission Mode and Continuous Transmission Mode

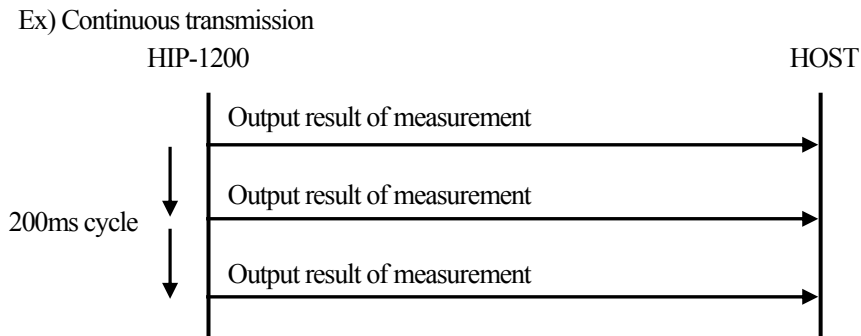
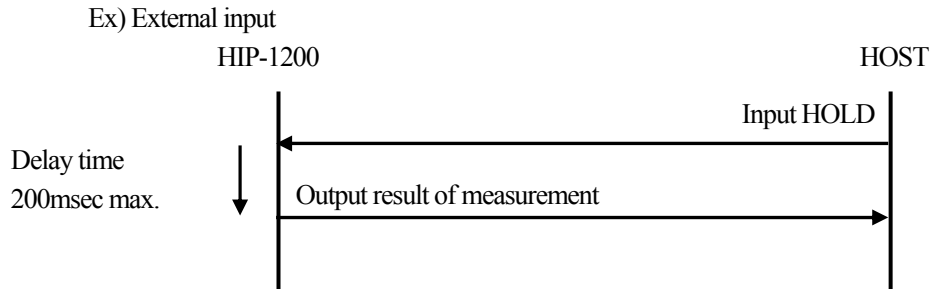

Single angle measurement and runout measurement data are sent in the communication format shown below.

HIP1200

G	,	*S	,	*X	,	*Y	,	*D	,	CR	LF
---	---	----	---	----	---	----	---	----	---	----	----

G : Header

*S : Judgment result "O"(OK), "N"(NG) , "E"(ERROR)

*X :

*Y :

±	0	.	0	0	0
---	---	---	---	---	---

*D :

±	0	.	0	0	0
---	---	---	---	---	---

 [SP] Space Character

SP	0	.	0	0	0
----	---	---	---	---	---

The format of the measured angle data (*X, *Y, *D, etc) varies by the selected unit display.

deg

±	0	.	0	0	0
±	0	.	0	0	0
SP	0	.	0	0	0

min+sec

±	0	0	0	0	0
±	0	0	0	0	0
SP	0	0	0	0	0

mrاد

±	0	0	.	0	0
±	0	0	.	0	0
SP	0	0	.	0	0

(Note)

- When judgment is E, measurements are "999999".

Multi-spot (relative) measurement data are sent in the communication format shown below.

HIP1200

G	,	*S	,	*X	,	*Y	,	*D	,	*L1	,	*L2	,	*L3	CR	LF
---	---	----	---	----	---	----	---	----	---	-----	---	-----	---	-----	----	----

G : Header

*S : Judgment result “O”(OK),”N”(NG) , ”E”(ERROR)

*X :	±	0	.	0	0	0
*Y :	±	0	.	0	0	0
*D :	SP	0	.	0	0	0
*L :	SP	0	.	0	0	0

[SP] Space Character

(Note)

- When judgment is E, measurements are “999999”.
- L1, L2, and L3 are left absent when there is only a single spot.
- L2 and L3 are left absent when there are two spots.

Multi-spot (absolute) measurement data are sent in the communication format shown below.

HIP1200

G	,	*S	,	*X1	,	*Y1	,	*D1	,	*X2	,	*Y2	,	*D2	,	*X3	,	*Y3	,	*D3	CR	LF
---	---	----	---	-----	---	-----	---	-----	---	-----	---	-----	---	-----	---	-----	---	-----	---	-----	----	----

G : Header

*S : Judgment result “O”(OK),”N”(NG) , ”E”(ERROR)

*X _n :	±	0	.	0	0	0
*Y _n :	±	0	.	0	0	0
*D _n :	SP	0	.	0	0	0

[n] Label Number

[SP] Space Character

(Note)

- When judgment is E, measurements are “999999”.
- When a label other than an error exists, the label outputs measured value.
- When only a single spot exists, X2 and subsequent data fields are left absent; when there are only two spots, X3 and subsequent data fields are left absent.

3 BEAM main beam measurement data are sent in the communication format shown below.

HIP1200

G	,	*S	,	*X	,	*Y	,	*D	,	CR	LF
---	---	----	---	----	---	----	---	----	---	----	----

G : Header

*S : Judgment results “O”(OK),”N”(NG) , ”E”(ERROR)

*X :

±	0	.	0	0	0
---	---	---	---	---	---

*Y :

±	0	.	0	0	0
---	---	---	---	---	---

*D :

SP	0	.	0	0	0
----	---	---	---	---	---

 [SP] Space Character

(Note)

- When judgment is E, measurements are “999999”.

3 BEAM sub-beam measurement data are sent in the communication format shown below.

HIP1200

G	,	*S	,	*T1	,	*T2	CR	LF
---	---	----	---	-----	---	-----	----	----

G : Header

*S : Judgment results “O”(OK),”N”(NG) , ”E”(ERROR)

*T1 :

±	0	0	.	0	0	0
---	---	---	---	---	---	---

 or

SP	±	0	.	0	0	0
----	---	---	---	---	---	---

*T2 :

±	0	0	.	0	0	0
---	---	---	---	---	---	---

SP	±	0	.	0	0	0
----	---	---	---	---	---	---

[SP] Space Character

T1 : Difference from basic θ angle

T2 : θ angle of \pm sub-beam

(Note)

- When judgment is E, measurements are “999999”.

12.3.2 Remote Control Mode

Ex) Read measured value

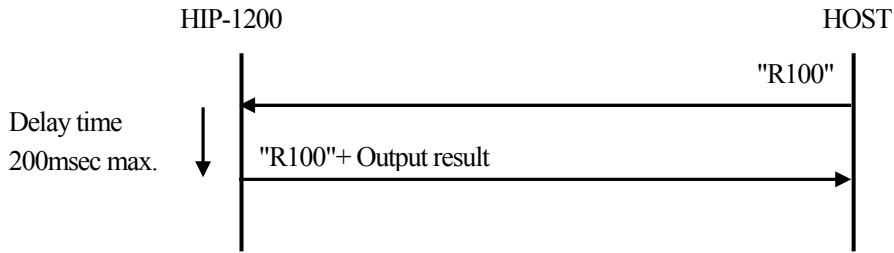

Ex) Zero set

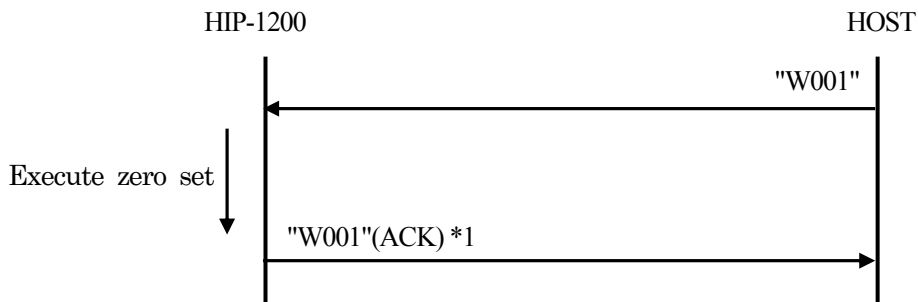

*1 An error command is returned if communication error exists.

Read Measured Value

Values from current angle measurement, runout measurement or 3 BEAM measurement are outputted.
 The sample response indicates an angle measurement (single spot measurement).
 The response follows the same format after the identifier (G).

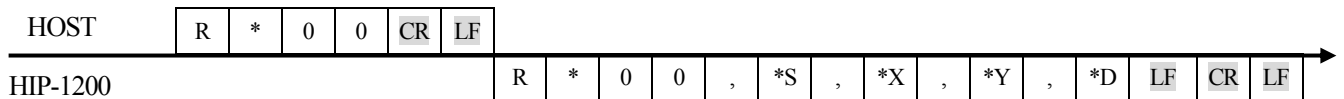

* : Symbol 1 : Angle Measurement , 2 : Runout Measurement , 3 : 3 BEAM Measurement

*S : "O"(OK), "N"(NG) , "E"(ERROR)

*X :

±	0	.	0	0	0
---	---	---	---	---	---

*Y :

±	0	.	0	0	0
---	---	---	---	---	---

*D :

SP	0	.	0	0	0
----	---	---	---	---	---

[SP] Space Character

(注)

- Values are displayed in the unit as set from the menu.
- When external incident is set, the range of reflection measurement is twice as broad as the standard setting using an internal light source.

Read Calibration Data

Calibration data is output.

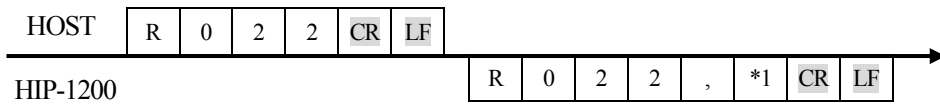

Read System Data

System data is output.

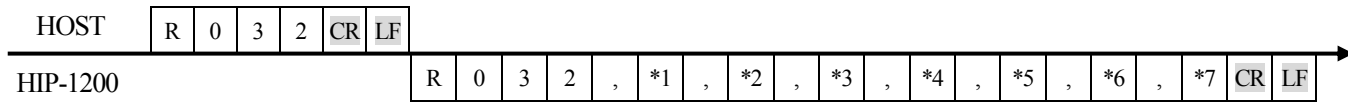

*1 : BINARY	2	0	0	30~254
*2 : LAC TYPE	0	1		0~11 (0.16~2.0)
*3 : ROTATION	0			0:OFF , 1: 90° CCW , 2: 90° CW
*4 : MIRRORING	0			0:X-Y OFF , 1:X ON , 2:Y ON , 3:X-Y ON
*5 : DISPLAY	1			0:OFF , 1:ON (display measurement results)
*6 : UNIT	1			0:deg , 1:min+sec , 2:mrad
*7 : DATA OUT	1			0: Stream, 1: I/O input

Reading measurement setting data individually

Current measurement setting data are outputted on the item by item basis.

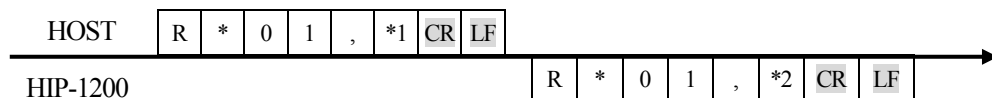

*1 : Item code

*1
*2

Item code list (shown below)

*2 : Setting

Varies by the item

Item Code List

No	Code	Item Name
1	01	Binarization level
2	02	Noise level
3	03	Criteria
4	04	Circle - Radius
5	05	Square - X L
6	06	Square - X H
7	07	Square - Y H
8	08	Square - Y L
9	09	Circle 2 - Radius
10	0A	Judgment X_Offset
11	0B	Judgment Y_Offset
12	0C	Noise level judgment or not
13	0D	Noise level upper limit
14	0E	Noise level lower limit
15	20	Measurement object (single or multi-spot)
16	21	Spot numbering method (area or angle)
17	22	Spot number for judgment
18	23	Method of center of gravity calculation
19	24	Application of averaging
20	25	Application of ZOOM
21	26	Sample size
22	27	Application of orbit width judgment
23	28	Method of orbit width calculation
24	29	Measurement range width X
25	2A	Measurement range width Y

No	Code	Item Name
26	2B	Measurement range width W
27	2C	Measurement range width L
28	2D	Method of main beam threshold calculation
29	2E	Main beam threshold
30	2F	Main beam judgment style (circle or square)
31	2G	Main beam measurement radius - X
32	2H	Main beam measurement radius - Y
33	2I	Basic θ angle
34	2J	Application of θ angle averaging
35	2K	Application of θ angle for judgment
36	2L	θ angle for judgment
37	2M	Application of graphic display of θ angle
38	2N	Range of graphic display of θ angle
39	2O	Luminance judgment or not
40	2P	Upper limit luminance
41	2Q	Lower limit luminance
42		
43		
44		
45		
46		
47		
48		
49		
50		

Reading all measurement setting data

Current setting is read out.

1) Angle Measurement

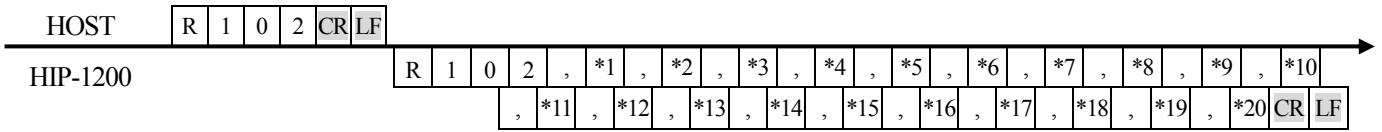

<p>*1 : BINARY</p> <p>*2 : NOIZE L-LEVEL</p> <p>*3 : NOIZE CHIGH</p> <p>*4 : NOIZE CLOW</p> <p>*5 : NOIZE CHECK</p> <p>*6 : AREA</p> <p>*7 : CIRCLE</p> <p>*8 : X-Y-XL</p> <p>*9 : X-Y-XH</p> <p>*10 : X-Y-YH</p> <p>*11 : X-Y-YL</p> <p>*12 : CIRCLE2</p> <p>*13 : X-OFFSET</p> <p>*14 : Y-OFFSET</p> <p>*15 : LABEL SEL.</p> <p>*16 : NUMBERING</p> <p>Ascending order of angles</p> <p>*17 : NUMBER</p> <p>*18 : MODE</p> <p>*19 : AVERAGE</p> <p>times</p> <p>*20 : ZOOM</p>	<table border="1" style="margin-bottom: 10px;"> <tr><td>1</td><td>1</td><td>1</td></tr> <tr><td>1</td><td>1</td><td>1</td></tr> <tr><td>1</td><td>1</td><td>1</td></tr> <tr><td>1</td><td>1</td><td>1</td></tr> <tr><td>0</td><td></td><td></td></tr> <tr><td>±</td><td>0</td><td>.</td><td>1</td><td>0</td><td>0</td></tr> <tr><td>±</td><td>0</td><td>.</td><td>1</td><td>0</td><td>0</td></tr> <tr><td>±</td><td>0</td><td>.</td><td>1</td><td>0</td><td>0</td></tr> <tr><td>±</td><td>0</td><td>.</td><td>1</td><td>0</td><td>0</td></tr> <tr><td>±</td><td>0</td><td>.</td><td>1</td><td>0</td><td>0</td></tr> <tr><td>±</td><td>0</td><td>.</td><td>1</td><td>0</td><td>0</td></tr> <tr><td>±</td><td>0</td><td>.</td><td>1</td><td>0</td><td>0</td></tr> <tr><td>±</td><td>0</td><td>.</td><td>1</td><td>0</td><td>0</td></tr> <tr><td>1</td><td></td><td></td><td></td><td></td><td></td></tr> </table> <table border="1" style="margin-bottom: 10px;"> <tr><td>1</td></tr> <tr><td>1</td></tr> <tr><td>1</td></tr> </table> <table border="1" style="margin-bottom: 10px;"> <tr><td>1</td></tr> <tr><td>1</td></tr> </table>	1	1	1	1	1	1	1	1	1	1	1	1	0			±	0	.	1	0	0	±	0	.	1	0	0	±	0	.	1	0	0	±	0	.	1	0	0	±	0	.	1	0	0	±	0	.	1	0	0	±	0	.	1	0	0	±	0	.	1	0	0	1						1	1	1	1	1	<p>30~254</p> <p>30 ~ 254 or 30 ~ CLOW</p> <p>CLOW ~ 254</p> <p>30 ~ CHIGH</p> <p>0:OFF , 1:ON</p> <p>0:OFF , 1:Circle , 2:Square</p> <p>0.001~LAC angle</p> <p>-LAC angle~XH</p> <p>XL~LAC angle</p> <p>YL~LAC angle</p> <p>-LAC angle ~ YH</p> <p>0.001~LAC angle</p> <p>-LAC angle~0.000~LAC angle</p> <p>-LAC angle~0.000~LAC angle</p> <p>0: Single-spot , 1 : Multi-spot (relative) , 2 : Multi-spot (absolute)</p> <p>0: Descending order of areas , 1:</p> <p>0:ALL , 1:1 , 2:2 , 3:3</p> <p>0:Center of area , 1:Luminance centroid , 2:Luminance peak</p> <p>0:OFF , 1: 2 times , 2: 4 times , 3:8</p> <p>0:OFF , 1: X4 , 2: X8 , 3:X16</p>
1	1	1																																																																										
1	1	1																																																																										
1	1	1																																																																										
1	1	1																																																																										
0																																																																												
±	0	.	1	0	0																																																																							
±	0	.	1	0	0																																																																							
±	0	.	1	0	0																																																																							
±	0	.	1	0	0																																																																							
±	0	.	1	0	0																																																																							
±	0	.	1	0	0																																																																							
±	0	.	1	0	0																																																																							
±	0	.	1	0	0																																																																							
1																																																																												
1																																																																												
1																																																																												
1																																																																												
1																																																																												
1																																																																												

2) Runout Measurement

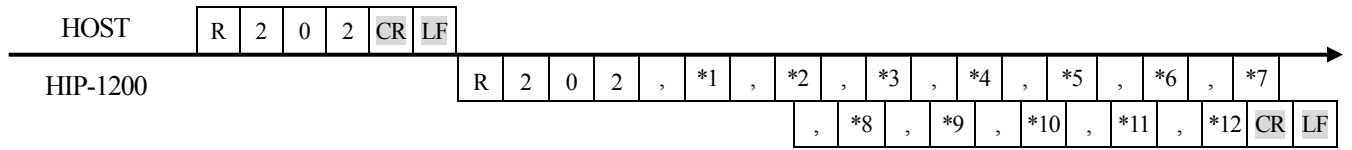

- | | | |
|-----------------|--------------|-------------------------------|
| *1 : SAMPLE | 9 9 9 | 1~999 |
| *2 : BINARY | 2 5 3 | 30~254 |
| *3 : AREA | 1 | 0:OFF , 1: Circle , 2: Square |
| *4 : CIRCLE | ± 0 . 1 0 0 | 0.001~LAC angle |
| *5 : X-Y-XL | ± 0 . 1 0 0 | -LAC angle~XH |
| *6 : X-Y-XH | ± 0 . 1 0 0 | XL~LAC angle |
| *7 : X-Y-YH | ± 0 . 1 0 0 | YL~LAC angle |
| *8 : X-Y-YL | ± 0 . 1 0 0 | -LAC angle~YH |
| *9 : WIDTH | 0 | 0 : OFF , 1 : ON |
| *10 : CALC MODE | 0 | 0 : FILL , 1 : FEAT |
| *11 : wX | SP 0 . 1 0 0 | 0.001~LAC angle |
| : wW | SP 0 . 1 0 0 | 0.001~LAC angle |
| *12 : wY | SP 0 . 1 0 0 | 0.001~LAC angle |
| : wL | SP 0 . 1 0 0 | 0.001~LAC angle |

[SP] Space Character

3) 3 BEAM Measurement

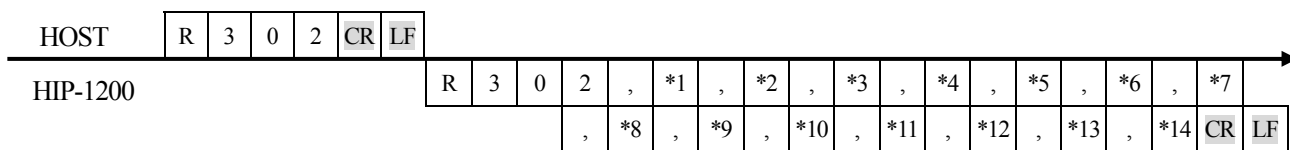

*1 : MODE	1																			0:Level , 1:Max%	
*2 : THRESHOLD	1	0	0																		Threshold (30 ~ 254 or 12 ~ 99)
*3 : NLEVEL HIGH																					Upper limit (lower limit ~ 4)
*4 : NLEVEL LOW																					Lower limit (1 ~ upper limit)
*5 : NLEVEL FLG																					0:OFF , 1:ON
*6 : AREA	0																				0:OFF , 1:Ellipse , 2:Square
*7 : X	0	.	5	0	0																0.001 ~ LAC angle
*8 : Y	0	.	5	0	0																0.001 ~ LAC angle
*9 : θBASIS	-	9	0	.	0	0	0														-90.000 ~ 90.000
*10 : AVERAGE	1																				0:OFF , 1:4 , 2:6 , 3:8
*11 : JUDGE ON/OFF	1																				0:OFF , 1:ON
*12 : JUDGE RANGE	1	0	.	0	0	0															0.001 ~ 90.000
*13 : BAR ON/OFF	1																				0:OFF , 1:ON
*14 : BAR RANGE	SP	0	.	1	0																0.10 ~ 10.00

Zero Set

This sets the zero point to the detected light in the monitor.

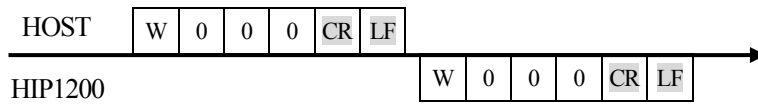

Zero Reset

This sets the zero point to the center of the monitor.

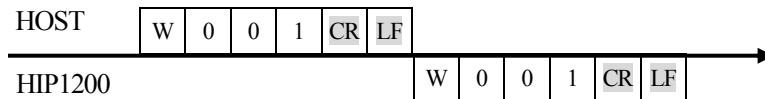

Function Change

It changes to the measurement function.

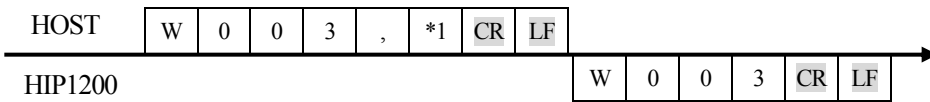

*1 : Mode 1: Angle Measurement , 2: Runout Measurement , 3: 3 BEAM Measurement

Measurement Stop

The measurement is stopped.

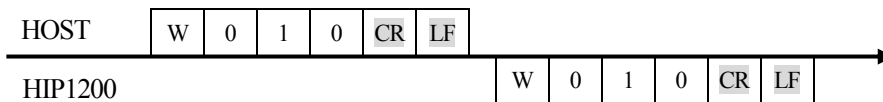

Measurement Start

The measurement starts.

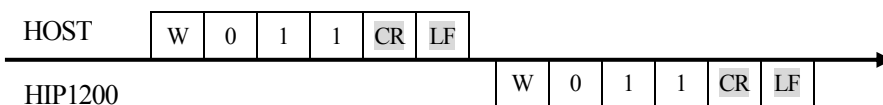

Remote Off

A remote controlled function is released.

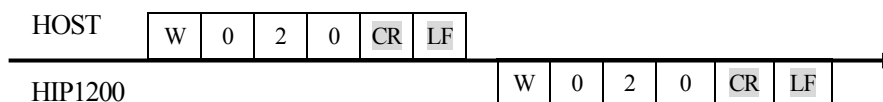

Calibration Data Change

The calibration data is changed.

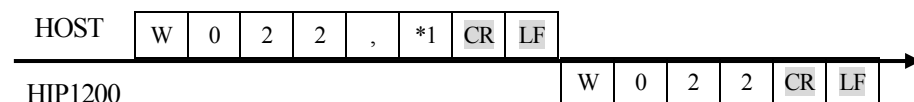

*1 : Calibration data

0	.	0	0	0	0	0	0
---	---	---	---	---	---	---	---

File Save

This saves the current settings in the specified file (1 File No 5)

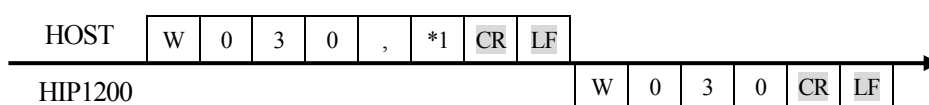

*1 : File No 1~5

File Load & Function Change

Change to the specified file and specified measurement function.

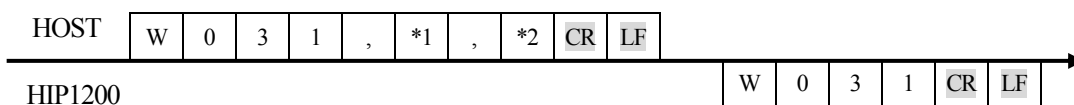

*1 : Load file number 1~5

*2 : Mode 1: Angle Measurement, 2: Runout Measurement, 3: 3 BEAM Measurement

System Data Change

The system data is changed.

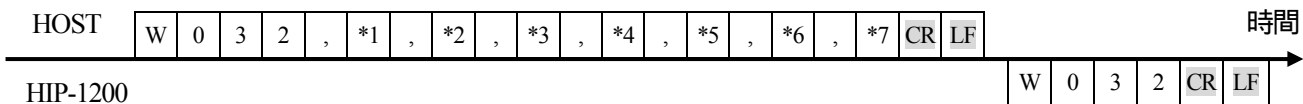

- *1 : BINARY

2	0	0
---	---	---

 30~254
- *2 : LAC TYPE

0	1
---	---

 0~11 (0.16~2.0)
- *3 : ROTATION

0

 0:OFF , 1: 90° CCW , 2: 90° CW
- *4 : MIRRORING

0

 0:X-Y OFF , 1:X ON , 2:Y ON , 3:X-Y ON
- *5 : DISPLAY

1

 0:OFF , 1:ON (display measurement results)
- *6 : UNIT

1

 0:deg , 1:min+sec , 2:mrاد
- *7 : DATA OUT

1

 0: Stream , 1: I/O input

Changing settings individually

Current measurement setting data are changed by each items.

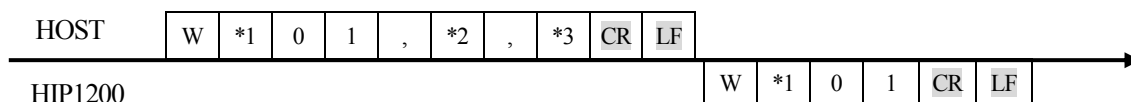

*1 : Identifying code 1: Angle Measurement, 2: Runout Measurement, 3: 3 BEAM Measurement

*2 : Item code Item code list (shown below)

*3 : Change value Change value of the specified item

Item Code List

No	Code	Item Name
1	01	Binarization level
2	02	Noise level
3	03	Criteria
4	04	Circle - Radius
5	05	Square - X L
6	06	Square - X H
7	07	Square - Y H
8	08	Square - Y L
9	09	Circle 2 - Radius
10	0A	Judgment X_Offset
11	0B	Judgment Y_Offset
12	0C	Noise level judgment or not
13	0D	Noise level upper limit
14	0E	Noise level lower limit
15	20	Measurement object (single or multi-spot)
16	21	Spot numbering method (area or angle)
17	22	Spot number for judgment
18	23	Method of center of gravity calculation
19	24	Application of averaging
20	25	Application of ZOOM
21	26	Sample size
22	27	Application of orbit width judgment
23	28	Method of orbit width calculation
24	29	Measurement range width X
25	2A	Measurement range width Y

No	Code	Item Name
26	2B	Measurement range width W
27	2C	Measurement range width L
28	2D	Method of main beam threshold calculation
29	2E	Main beam threshold
30	2F	Main beam judgment style (circle or square)
31	2G	Main beam measurement radius - X
32	2H	Main beam measurement radius - Y
33	2I	Basic θ angle
34	2J	Application of θ angle averaging
35	2K	Application of θ angle for judgment
36	2L	θ angle for judgment
37	2M	Application of graphic display of θ angle
38	2N	Range of graphic display of θ angle
39	2O	Luminance judgement or not
40	2P	Upper limit luminance
41	2Q	Lower limit luminance
42		
43		
44		
45		
46		
47		
48		
49		
50		

Changing all settings

All measurement setting data are changed as a group.

1) Angle Measurement

W	1	0	2	,	*1	,	*2	,	*3	,	*4	,	*5	,	*6	,	*7	,	*8	,	*9	,	*10
HOST	HOST	,	*11	,	*12	,	*13	,	*14	,	*15	,	*16	,	*17	,	*18	,	*19	,	*20	CR	LF

W	1	0	2	CR	LF
---	---	---	---	----	----

<p>*1 : BINARY</p> <p>*2 : NOIZE L-LEVEL</p> <p>*3 : NOIZE CHIGH</p> <p>*4 : NOIZE CLOW</p> <p>*5 : NOIZE CHECK</p> <p>*6 : AREA</p> <p>*7 : CIRCLE</p> <p>*8 : X-Y-XL</p> <p>*9 : X-Y-XH</p> <p>*10 : X-Y-YH</p> <p>*11 : X-Y-YL</p> <p>*12 : CIRCLE2</p> <p>*13 : X-OFFSET</p> <p>*14 : Y-OFFSET</p> <p>*15 : LABEL SEL.</p> <p>*16 : NUMBERING</p> <p>Ascending order of angles</p> <p>*17 : NUMBER</p> <p>*18 : MODE</p> <p>*19 : AVERAGE</p> <p>times</p> <p>*20 : ZOOM</p>	<table border="1" style="margin-bottom: 5px;"> <tr><td>1</td><td>1</td><td>1</td></tr> </table> <table border="1" style="margin-bottom: 5px;"> <tr><td>1</td><td>1</td><td>1</td></tr> </table> <table border="1" style="margin-bottom: 5px;"> <tr><td>1</td><td>1</td><td>1</td></tr> </table> <table border="1" style="margin-bottom: 5px;"> <tr><td>1</td><td>1</td><td>1</td></tr> </table> <table border="1" style="margin-bottom: 5px;"> <tr><td>0</td></tr> </table> <table border="1" style="margin-bottom: 5px;"> <tr><td>±</td><td>0</td><td>.</td><td>1</td><td>0</td><td>0</td></tr> </table> <table border="1" style="margin-bottom: 5px;"> <tr><td>±</td><td>0</td><td>.</td><td>1</td><td>0</td><td>0</td></tr> </table> <table border="1" style="margin-bottom: 5px;"> <tr><td>±</td><td>0</td><td>.</td><td>1</td><td>0</td><td>0</td></tr> </table> <table border="1" style="margin-bottom: 5px;"> <tr><td>±</td><td>0</td><td>.</td><td>1</td><td>0</td><td>0</td></tr> </table> <table border="1" style="margin-bottom: 5px;"> <tr><td>±</td><td>0</td><td>.</td><td>1</td><td>0</td><td>0</td></tr> </table> <table border="1" style="margin-bottom: 5px;"> <tr><td>±</td><td>0</td><td>.</td><td>1</td><td>0</td><td>0</td></tr> </table> <table border="1" style="margin-bottom: 5px;"> <tr><td>±</td><td>0</td><td>.</td><td>1</td><td>0</td><td>0</td></tr> </table> <table border="1" style="margin-bottom: 5px;"> <tr><td>±</td><td>0</td><td>.</td><td>1</td><td>0</td><td>0</td></tr> </table> <table border="1" style="margin-bottom: 5px;"> <tr><td>±</td><td>0</td><td>.</td><td>1</td><td>0</td><td>0</td></tr> </table> <table border="1" style="margin-bottom: 5px;"> <tr><td>1</td></tr> </table> <table border="1" style="margin-bottom: 5px;"> <tr><td>1</td></tr> </table> <table border="1" style="margin-bottom: 5px;"> <tr><td>1</td></tr> </table> <table border="1" style="margin-bottom: 5px;"> <tr><td>1</td></tr> </table> <table border="1" style="margin-bottom: 5px;"> <tr><td>1</td></tr> </table> <table border="1"> <tr><td>1</td></tr> </table>	1	1	1	1	1	1	1	1	1	1	1	1	0	±	0	.	1	0	0	±	0	.	1	0	0	±	0	.	1	0	0	±	0	.	1	0	0	±	0	.	1	0	0	±	0	.	1	0	0	±	0	.	1	0	0	±	0	.	1	0	0	±	0	.	1	0	0	1	1	1	1	1	1	<p>30~254</p> <p>30 ~ 254 or 30 ~ CLOW</p> <p>CLOW ~ 254</p> <p>30 ~ CHIGH</p> <p>0:OFF , 1:ON</p> <p>0:OFF , 1:円 , 2:Square</p> <p>0.001~LAC angle</p> <p>-LAC angle~XH</p> <p>XL~LAC angle</p> <p>YL~LAC angle</p> <p>-LAC angle ~ YH</p> <p>0.001~LAC angle</p> <p>-LAC angle~0.000~LAC angle</p> <p>-LAC angle~0.000~LAC angle</p> <p>0: Single-spot, 1 : Multi-spot (relative), 2 : Multi-spot (absolute)</p> <p>Descending order of areas , 1:</p> <p>0:ALL , 1:1 , 2:2 , 3:3</p> <p>0:Center of area , 1:Luminance centroid , 2:Luminance peak</p> <p>0:OFF , 1: 2 times , 2: 4 times , 3:8</p> <p>0:OFF , 1: X4 , 2: X8 , 3:X16</p>
1	1	1																																																																									
1	1	1																																																																									
1	1	1																																																																									
1	1	1																																																																									
0																																																																											
±	0	.	1	0	0																																																																						
±	0	.	1	0	0																																																																						
±	0	.	1	0	0																																																																						
±	0	.	1	0	0																																																																						
±	0	.	1	0	0																																																																						
±	0	.	1	0	0																																																																						
±	0	.	1	0	0																																																																						
±	0	.	1	0	0																																																																						
±	0	.	1	0	0																																																																						
1																																																																											
1																																																																											
1																																																																											
1																																																																											
1																																																																											
1																																																																											

2) Runout Measurement

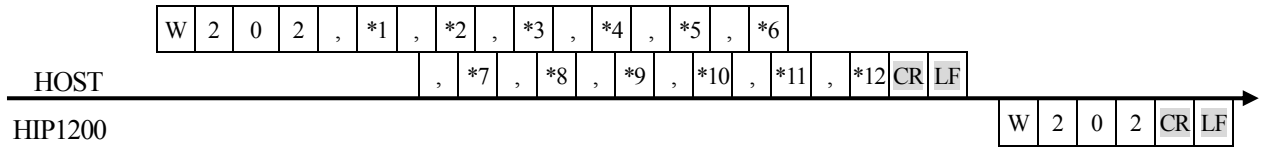

*1 : SAMPLE

9	9	9
---	---	---

*2 : BINARY

2	5	3
---	---	---

*3 : AREA

1		
---	--	--

0:OFF , 1:Circle , 2:Square

*4 : CIRCLE

±	0	.	1	0	0
---	---	---	---	---	---

0.001~LAC angle

*5 : X-Y-XL

±	0	.	1	0	0
---	---	---	---	---	---

-LAC angle~XH

*6 : X-Y-XH

±	0	.	1	0	0
---	---	---	---	---	---

XL~LAC angle

*7 : X-Y-YH

±	0	.	1	0	0
---	---	---	---	---	---

YL~LAC angle

*8 : X-Y-YL

±	0	.	1	0	0
---	---	---	---	---	---

-LAC angle~YH

*9 : WIDTH

0		
---	--	--

0 : OFF , 1 : ON

*10 : CALC MODE

0		
---	--	--

0 : FILL , 1 : FEAT

*11 : wX

SP	0	.	1	0	0
----	---	---	---	---	---

0.001~LAC angle

: wW

SP	0	.	1	0	0
----	---	---	---	---	---

0.001~LAC angle

*12 : wY

SP	0	.	1	0	0
----	---	---	---	---	---

0.001~LAC angle

: wL

SP	0	.	1	0	0
----	---	---	---	---	---

0.001~LAC angle

[SP] Space Character

3) 3 BEAM Measurement

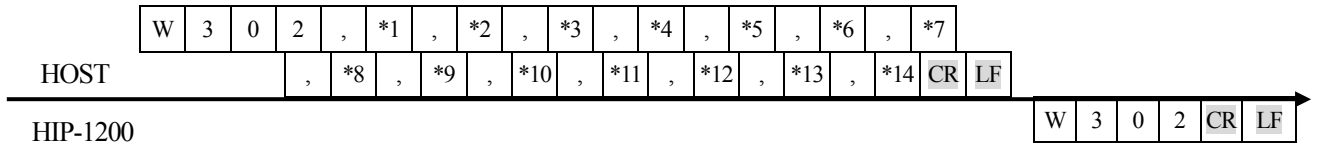

*1 : MODE	1						0:Level, 1:Max%
*2 : THRESHOLD	1	0	0				Threshold (30 ~ 254 or 12 ~ 99)
*3 : NLEVEL HIGH							Upper limit (lower limit ~ 4)
*4 : NLEVEL LOW							Lower limit (1 ~ upper limit)
*5 : NLEVEL FLG							0:OFF , 1:ON
*6 : AREA	0						0:OFF , 1:Ellipse , 2:Square
*7 : X	0	.	5	0	0		0.001 ~ LAC angle
*8 : Y	0	.	5	0	0		0.001 ~ LAC angle
*9 : θBASIS	-	9	0	.	0	0 0	-90.000 ~ 90.000
*10 : AVERAGE	1						0:OFF , 1:4 , 2:6 , 3:8
*11 : JUDGE ON/OFF	1						0:OFF , 1:ON
*12 : JUDGE RANGE	1	0	.	0	0 0		0.001 ~ 90.000
*13 : BAR ON/OFF	1						0:OFF , 1:ON
*14 : BAR RANGE	SP	0	.	1	0		0.10 ~ 10.00

OFFSETTILT Switch to the judgment 1

Switch the tolerance from judgment range 2 (d1,d2,X-Y) to judgement range 1 (d1) at the OFFSETTILT measurement.

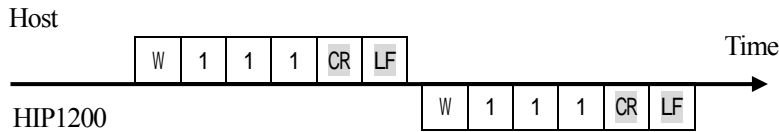

OFFSETTILT Switch to the judgment 2

Switch the tolerance from judgment range 1 (d1) to judgment range 2 (d1,d2,X-Y) at the OFFSETTILT measurement.

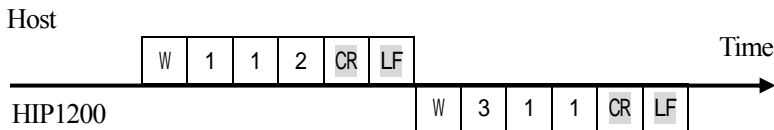

Main-beam Measurement Change

Operation changes from 3 BEAM sub-beam to main beam measurement.

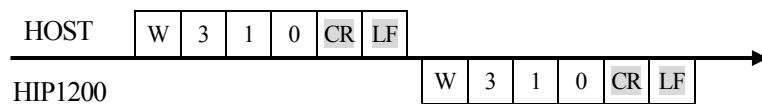

Sub -beam Measurement Change

Operation changes from 3 BEAM main beam to sub-beam measurement.

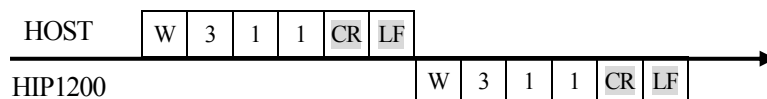

Averaging of 3 BEAM measurement

Averaging of 3 BEAM sub-beam measurement is performed.

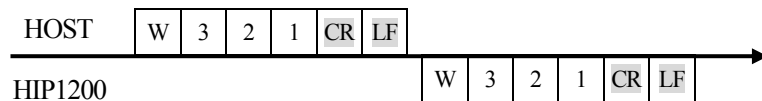

Cancelling the averaging of 3 BEAM measurement

Averaging of 3 BEAM sub-beam measurement is cancelled.

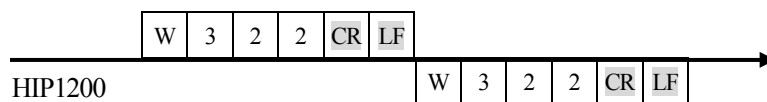

Communication errors

An error is returned from the unit in the format shown below when the command fails to receive or execute normally.

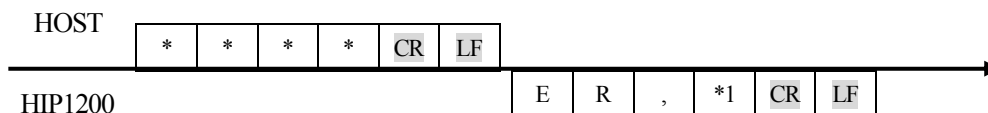

*Error codes and types at

1: Communication error

- 92 or more characters received between ID Code character and [CRLF]
- No characters received within 1 second after ID Code is received
- Overrun error or framing error

2: Setting data error

- A set value falls outside of the setting range
(When Setting command is used, this error may occur when the relative size is invalid.)

3: Command format error

- The number of characters between ID Code character and [CRLF] is invalid
- Setting data is missing or characters other than numeric characters are used in Set type command
- The character following ID Code is not in the above list

4: Execution error

- Zero set failed during “WA” command execution as no light dot was detected.
- No data have been saved under the specified file number.

12.4. Data Collection Software

Data Collection Software is an Excel macro program for receiving results of measurement that are sent by serial output.

The software can be downloaded from Suruga Seiki OST Division's homepage (<http://www.surugaost.jp/>).

12.4.1 Operating environment and operation

You will need Microsoft(R) Excel 2000 or later versions to run the software. You will also need a D-sub 9-pin cross cable for connection to the PC.

12.4.2 Start

Start Microsoft(R) Excel file "HIP-1200 Communication with macros enabled.

12.4.3 Setting (See "12.1 Serial Interface" about setting in the image processor side)

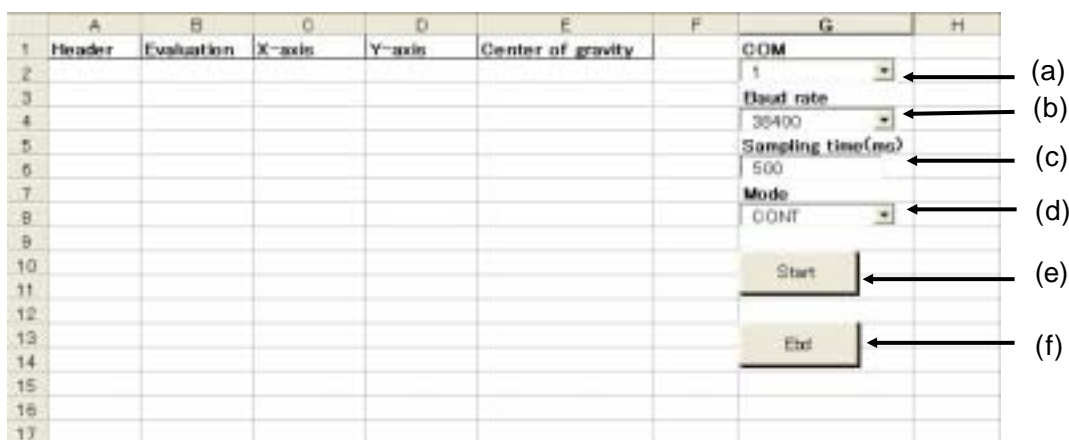

(a) COM

Set the COM port number of the PC connected to HIP-1200.

(b) Baud rate

Set the baud rate of communication set on the HIP-1200.

(c) Sampling time (ms)

Set the interval for acquiring results of measurement sent continuously from the HIP-12500.

(d) Mode

SINGLE: Receive data for a single result when START button is pressed; end when reception is completed.

* Enabled only when the HIP-1200 is in Remote Control mode.

CONT: Receive data from the HIP-1200 when START button is pressed; continue receiving data until END button is pressed (up to the end line on Excel; 65535th line on Excel 2000).

* Enabled only when the HIP-1200 is in "STREAM" mode and set for continuous transmission.

(e) Start button

Press "Start Communication" button in Microsoft(R) Excel file "HIP-1200 Communication to start receiving data.

(f) End button

Press "End Communication" button in Microsoft(R) Excel file "HIP-1200 Communication to end receive data.

12.5. I/O

The zero point setting and serial output of measured values are enabled when the input terminal pins A, B, D and the COM terminal pin E are shorted or open-ended.

The NG output from pin C will remain as long as NG decision lasts.

Pin D allows runout measurement to start.

12.5.1 Operation Timing Chart

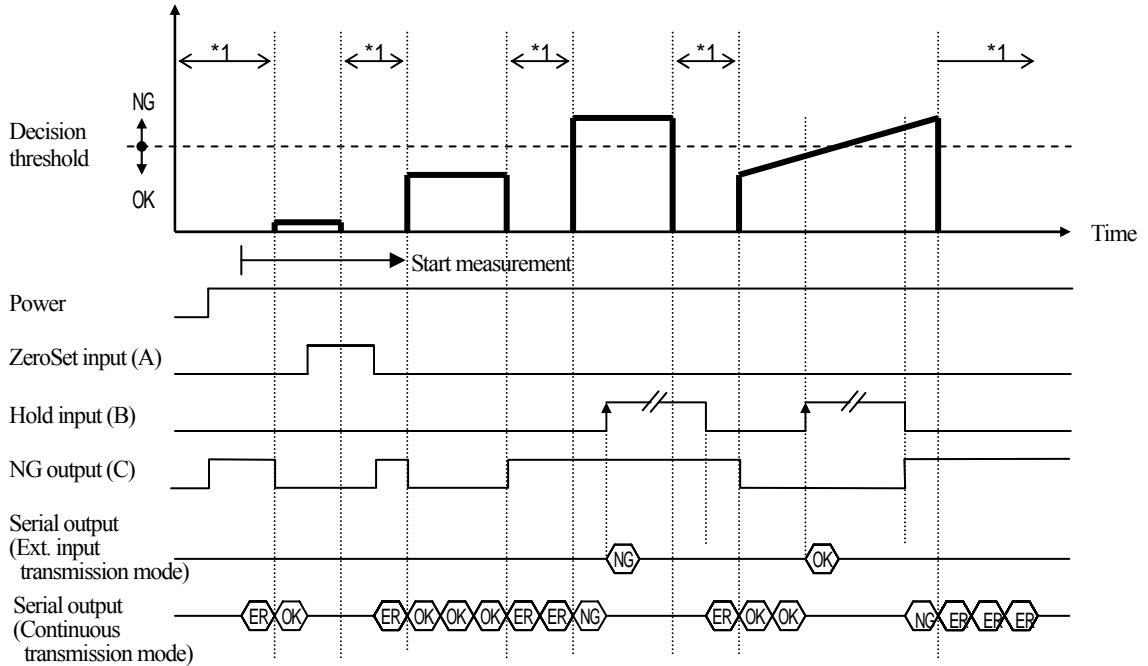

*1: Period without detected light

(Note)

- Input signals must remain ON for at least 100ms.
- Delay of NG output: There may be a delay of 200ms maximum from the Hold input signal to the registration of NG output signal.

12.5.2 Electrical Specification

Output: Max Load Current 100mA, Max Voltage 30VDC, Residual Voltage 1.2V and less

Input must be achieved by shorting (ON) or open-ending (OFF) the input terminal pins (A, B, D) and COM terminal pin (E). Use no-voltage contacts for shorting. No-voltage contacts must accept 5mA or higher current with the leakage current of no higher than 0.1mA.

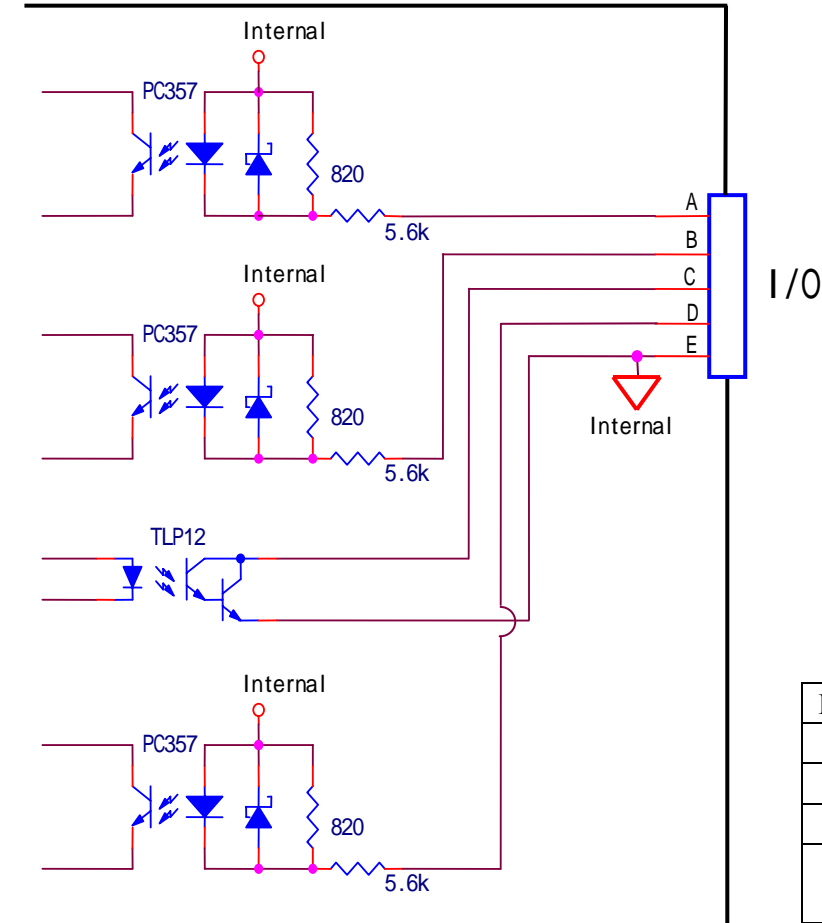

Pin No.	Signal Name
A	ZERO Set Input
B	Hold Input
C	NG Output
D	Measurement Start (Runout Measurement Onry)
E	Common (Internal 0VDC)

Connector Model : R03-R5F (Tajimi Electronics)

Compatible Connector Model : R03-PB5M (Tajimi Electronics)

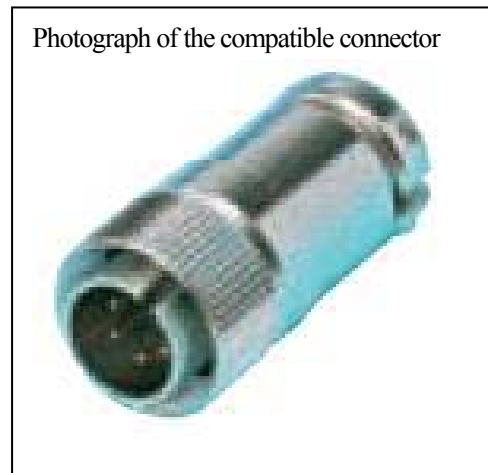
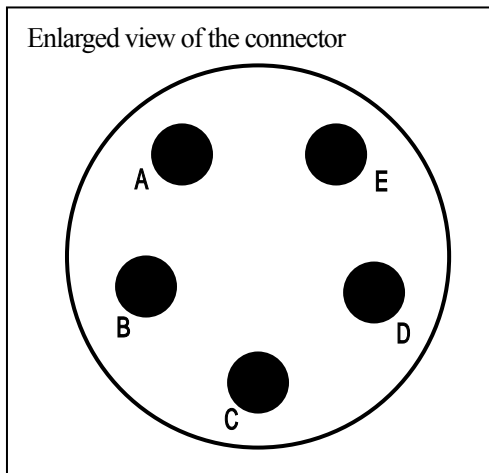

13. Troubleshooting

Case	Probable Causes	Countermeasure
No power supply	AC adapter is disconnected.	Securely connect to the wall outlet.
No light spot displayed in the screen	Connector cable is disconnected	Connect the cable correctly.
	Laser ON/OFF switch is set to OFF.	Set laser ON/OFF switch to ON.
	End of the laser life	Contact Suruga Seiki.
Monitor display problem	No images received from the auto collimator.	Connect the cable correctly.
Hard to detect laser light	Reflectance of the object is too low.	Adjust the variable aperture of the auto collimator or change the light intensity using the volume.
	Shutter speed is too slow.	Adjust the shutter speed by turning the shutter switch of the auto collimator.

< Revision History >

Edition	Date	Revised Content
First Edition	03/28/2008	New Document
2 nd Edition	04/22/2008	Section of luminance upper/lower judgement added (angle and 3-BEAM measurements)
3 rd Edition	05/13/2008	Basic tilt angle measurement function at the zero point added
4 th Edition	05/27/2008	Explanation and definition of the zero point added For 3 BEAM measurement screen displays change the place The command format that switched judgment of OFFSETTIL added.
5 th Edition	07/22/2008	Explanation of the ZERO SET different position by centroid estimation.

For More Information Call to us:

SURUGA SEIKI CO., LTD.

Overseas Section, OST Division

3F KonanYKBldg,2,4,12,Konan,Minato-ku, Tokyo, 108-0075 Japan

TEL : +81-3-6711-5014

FAX : +81-3-6711-5021

URL : <http://www.suruga-ost.com/>

E-mail : e-ost@suruga-g.co.jp